

ASME B16.9-2001

# FACTORY-MADE WROUGHT BUTTWELDING FITTINGS

AN AMERICAN NATIONAL STANDARD



The American Society of  
Mechanical Engineers



A N A M E R I C A N N A T I O N A L S T A N D A R D

# FACTORY-MADE WROUGHT BUTTWELDING FITTINGS

**ASME B16.9-2001**

Date of Issuance: June 22, 2001

This Standard will be revised when the Society approves the issuance of a new edition. There will be no addenda issued to this edition. The next edition of this Standard is scheduled for publication in 2005.

ASME will issue written replies to inquiries concerning interpretation of technical aspects of this Standard.

ASME is the registered trademark of The American Society of Mechanical Engineers.

This code or standard was developed under procedures accredited as meeting the criteria for American National Standards. The Standards Committee that approved the code or standard was balanced to assure that individuals from competent and concerned interests have had an opportunity to participate. The proposed code or standard was made available for public review and comment that provides an opportunity for additional public input from industry, academia, regulatory agencies, and the public-at-large.

ASME does not "approve," "rate," or "endorse" any item, construction, proprietary device, or activity.

ASME does not take any position with respect to the validity of any patent rights asserted in connection with any items mentioned in this document, and does not undertake to insure anyone utilizing a standard against liability for infringement of any applicable letters patent, nor assume any such liability. Users of a code or standard are expressly advised that determination of the validity of any such patent rights, and the risk of infringement of such rights, is entirely their own responsibility.

Participation by federal agency representative(s) or person(s) affiliated with industry is not to be interpreted as government or industry endorsement of this code or standard.

ASME accepts responsibility for only those interpretations of this document issued in accordance with the established ASME procedures and policies, which precludes the issuance of interpretations by individuals.

No part of this document may be reproduced in any form,  
in an electronic retrieval system or otherwise,  
without the prior written permission of the publisher.

The American Society of Mechanical Engineers  
Three Park Avenue, New York, NY 10016-5990

Copyright © 2001 by  
THE AMERICAN SOCIETY OF MECHANICAL ENGINEERS  
All Rights Reserved  
Printed in U.S.A.

## FOREWORD

In 1921, the American Engineering Standards Committee, later American Standards Association (ASA), organized Sectional Committee B16 to unify and further develop national standards for pipe flanges and fittings (and, later, for valves, gaskets, and valve actuators). Cosponsors of the B16 Committee were the American Society of Mechanical Engineers (ASME), the Heating and Piping Contractors National Association [now the Mechanical Contractors Association of America (MCAA)], and the Manufacturers Standardization Society of the Valve and Fittings Industry (MSS). Cosponsors were later designated as cosecretariat organizations.

Standardization of welding fittings was initiated in 1937 by a subgroup (designated Subgroup 6) of Subcommittee 3. After consideration of several drafts, a standard was approved by the Committee, cosponsors, and ASA, and published with the designation ASA B16.9-1940.

Revisions were made in 1950 and 1955 to add sizes up to NPS 24 and to complete coverage of fittings in some sizes. These revisions were approved and published as ASA B16.9-1951 and ASA B16.9-1958. With the subgroup now designated Subcommittee 6 (later Subcommittee F), further revisions were begun to clarify the intent of the standard, to add angularity tolerances, and to include fittings of different types (long radius-reducing elbows and crosses) and smaller sizes (NPS  $\frac{1}{4}$  and  $\frac{1}{2}$ ). This revision was published as ASA B16.9-1964 after ASA approval.

After reorganization of ASA, first as the United States of America Standards Institute (USASI), then as the American National Standards Institute (ANSI), with the Sectional Committee being redesignated as an American National Standards Committee, another revision increasing the size range to NPS 48 and revising the text for clarity was approved and published as ANSI B16.9-1971.

In 1975, Subcommittee F began a major revision to bring the standard up to date with current practice and usage. Common fractions were expressed as decimals (but without *intending higher precision*) and metric dimensional equivalents were added. Provisions for step-wise change of radius for NPS  $\frac{3}{4}$  long radius elbows and 180 deg returns were introduced. Following Standards Committee, cosecretariat, and ANSI approval, the revision was published as ANSI B16.9-1978. It was updated by a corrective addendum, B16.9a-1981, issued in February 1982.

In 1982, American National Standards Committee B16 was reorganized as an ASME Committee operating under procedures accredited by ANSI. In this Edition, the text has been revised and inch dimensions are established as the standard. Following approval by the Standards Committee and ASME, approval as an American National Standard was given by ANSI on November 12, 1986 with the new designation ASME/ANSI B16.9-1986.

In 1991 the Subcommittee reviewed the document and made a number of revisions. Dimensions for short pattern lap joints were also added to this 1993 Edition of the Standard.

In this 2001 Edition, short radius elbows and returns were added which includes all dimensions and tolerances of ASME B16.28-1994. This Edition also provides metric units as an independent but parallel alternative standard to U.S. Customary units and a Quality System Program Annex.

Requests for interpretation or suggestions for revision should be sent to the Secretary, B16 Committee, The American Society of Mechanical Engineers, Three Park Avenue, New York, NY 10016.

This Standard was approved as an American National Standard on April 6, 2001.

# ASME STANDARDS COMMITTEE B16

## Standardization of Valves, Flanges, Fittings, and Gaskets

(The following is the roster of the Committee at the time of approval of this Standard.)

### OFFICERS

**W. N. McLean**, *Chair*  
**H. R. Sonderegger**, *Vice Chair*  
**P. Reddington**, *Secretary*

### COMMITTEE PERSONNEL

**W. L. Ballis**, Columbia Gas Distribution Co.  
**J. E. Batey**, Union Carbide Corp.  
**K. M. Bell**, Underwriter's Laboratory, Inc.  
**M. L. Blair**, U.S. Coast Guard  
**R. R. Brodin**, Fisher Controls International, Inc.  
**A. Cohen**, Copper Development Association  
**W. C. Farrell, Jr.**, Consultant  
**C. E. Floren**, Mueller Co.  
**D. R. Frikken**, Monsanto Co.  
**M. W. Garland**, Frick Co.  
**J. B. Hagen**, ABS Americas  
**J. C. Inch**, Mueller Brass Co.  
**J. S. John**, J Square Engineering Co.  
**G. A. Jolly**, Vogt Valve Co.  
**W. G. Knecht**, Anchor/Darling Valve Co.  
**R. Koester**, The William Powell Co.  
**J. H. Longacre**, Nibco, Inc.  
**J. H. McCauley, Jr.**, James H. McCauley, Inc.  
**W. N. McLean**, Newco Valves  
**A. F. Rhodes**, Arnco Technology Trust  
**F. C. Rosch, Jr.**, Technicon Enterprises, Inc.  
**R. A. Schmidt**, Ladish Co.  
**H. R. Sonderegger**, Tyco Flow Control  
**W. M. Stephan**, Flexitallic Inc.  
**T. F. Stroud**, Ductile Iron Pipe Research Association  
**R. E. White**, Repairs, Inc.  
**D. A. Williams**, Southern Company Services  
**L. A. Willis**, Dow Chemical Co.

### SUBCOMMITTEE F — STEEL THREADED AND WELDING FITTINGS

**G. A. Jolly**, *Chairman*, Vogt Valve Co.  
**S. J. Rossi**, *Secretary*, The American Society of Mechanical Engineers  
**P. R. Benavides**, Tube Forgings of American, Inc.  
**G. A. Cuccio**, Capitol Manufacturing  
**J. P. Ellenberger**, WFI International  
**D. R. Frikken**, Monsanto Co.

**R. E. Johnson**, Consultant  
**R. C. Lafferty**, Penna Machine Works, Inc.  
**D. H. Monroe**, Consultant  
**R. A. Schmidt**, Ladish Co.  
**H. R. Sonderegger**, Tyco Flow Control  
**L. A. Willis**, Dow Chemical Co.  
**W. R. Worley**, Union Carbide

# CONTENTS

Foreword .....	iii
Committee Roster .....	v
<b>1 Scope .....</b>	<b>1</b>
1.1 General .....	1
1.2 Special Fittings .....	1
1.3 Fabricated Fittings .....	1
1.4 Standard Units .....	1
1.5 References .....	1
1.6 Service Conditions .....	1
1.7 Welding .....	1
1.8 Quality Systems .....	1
1.9 Convention .....	1
<b>2 Pressure Ratings .....</b>	<b>1</b>
2.1 Basis of Ratings .....	1
2.2 Design of Fittings .....	2
<b>3 Size .....</b>	<b>2</b>
<b>4 Marking .....</b>	<b>2</b>
4.1 Standard Marking .....	2
4.2 Exceptions .....	2
4.3 Depth of Stamping .....	2
4.4 Compliance .....	2
<b>5 Material .....</b>	<b>2</b>
<b>6 Fitting Dimensions .....</b>	<b>3</b>
6.1 General .....	3
6.2 Special Dimensions .....	3
<b>7 Surface Contours .....</b>	<b>3</b>
<b>8 End Preparation .....</b>	<b>3</b>
<b>9 Design Proof Test .....</b>	<b>3</b>
9.1 Required Tests .....	3
9.2 Test Assembly .....	3
9.3 Test Procedure .....	3
9.4 Applicability of Test Results .....	4
<b>10 Production Tests .....</b>	<b>5</b>



<b>11 Tolerances</b> .....	5
<b>Figure</b>	
1 Maximum Envelope for Welding End Transitions .....	5
<b>Tables</b>	
1 Welding Bevels and Root Face .....	4
2 Tolerances .....	6
3 Dimensions of Long Radius Elbows .....	8
4 Dimensions of Long Radius-Reducing Elbows .....	9
5 Dimensions of Long Radius Returns .....	10
6 Dimensions of Short Radius Elbows .....	10
7 Dimensions of Short Radius 180 Deg Returns .....	11
8 Dimensions of Straight Tees and Crosses .....	11
9 Dimensions of Reducing Outlet Tees and Reducing Outlet Crosses .....	12
10 Dimensions of Lap Joint Stub Ends .....	17
11 Dimensions of Caps .....	18
12 Dimensions of Reducers .....	19
<b>Mandatory Appendices</b>	
I Inch Tables .....	21
II References .....	35
<b>Nonmandatory Appendices</b>	
A Quality System Program .....	36

# FACTORY-MADE WROUGHT BUTTWELDING FITTINGS

## 1 SCOPE

### 1.1 General

This Standard covers overall dimensions, tolerances, ratings, testing, and markings for wrought factory-made butt welding fittings in sizes NPS  $\frac{1}{2}$  through 48 (DN 15 through 1200).

### 1.2 Special Fittings

Fittings may be made to special dimensions, sizes, shapes, and tolerances by agreement between the manufacturer and the purchaser.

### 1.3 Fabricated Fittings

Fabricated laterals and other fittings employing circumferential or intersection welds are considered pipe fabrication, and are not within the scope of this Standard.

### 1.4 Standard Units

The values stated in either metric or U.S. Customary units are to be regarded separately as standard. Within the text, the U.S. Customary units are shown in parentheses. The values stated in each system are not exact equivalents; therefore, each system must be used independently of the other. Combining values from the two systems may result in nonconformance with this Standard.

The designations for pressure rating and size are Class and NPS for both metric and customary dimensioned fittings. The designations PN and DN used in international standards are shown for reference convenience.

### 1.5 References

**1.5.1 Referenced Standards.** Standards and specifications adopted by reference in this Standard are shown in Mandatory Appendix II. It is not considered practical to identify the specific edition of each standard and specification in the individual references. Instead, the specific edition reference is identified in Mandatory Appendix II. A product made in conformance with a prior edition of reference standards and in all other respects conforming to this Standard will be considered to be in conformance.

**1.5.2 Codes and Regulations.** A fitting used under the jurisdiction of the ASME Boiler and Pressure Vessel Code, the ASME Code for Pressure Piping, or a governmental regulation is subject to any limitation of that code or regulation. This includes any maximum temperature limitation, or rule governing the use of a material at low temperature.

### 1.6 Service Conditions

Criteria for selection of fitting types and materials suitable for particular fluid service are not within the scope of this Standard.

### 1.7 Welding

Installation welding requirements are outside the scope of this Standard.

### 1.8 Quality Systems

Nonmandatory requirements relating to the fitting manufacturer's Quality System Program are described in Nonmandatory Appendix A.

### 1.9 Convention

For the purpose of determining conformance with this Standard, the convention for fixing significant digits where limits, maximum or minimum values, are specified shall be rounded off as defined in ASTM E 29. This requires that an observed or calculated value shall be "rounded off" to the nearest unit in the last right-hand digit used in expressing the limit. Decimal value in the last and tolerances do not imply a particular method of measurement.

## 2 PRESSURE RATINGS

### 2.1 Basis of Ratings

The allowable pressure ratings for fittings designed in accordance with this Standard may be calculated as for straight seamless pipe of equivalent material (as shown by comparison of composition and mechanical properties in the respective material specifications) in accordance with the rules established in the applicable

sections of ASME B31, Code for Pressure Piping. For the calculation, applicable data for the pipe size, wall thickness, and material that is equivalent to that of the fitting shall be used. Pipe size, wall thickness (or schedule number), and material identity on the fittings are in lieu of pressure rating markings.

## 2.2 Design of Fittings

The design of fittings shall be established by mathematical analyses (e.g. ASME B16.49 for bends) contained in nationally recognized pressure vessel or piping codes or at the manufacturer's option by proof testing in accordance with section 9 of this Standard. In order to meet design or manufacturing requirements, it is expected that some portion of formed fittings may have to be thicker than the pipe wall with which the fittings is intended to be used. The mathematical analyses, if used, may take into account such thicker sections. Records of mathematical analysis and/or successful proof test data shall be available at the manufacturer's facility for inspection by the purchaser.

## 3 SIZE

NPS, followed by a dimensionless number, is the designation for nominal fitting size. NPS is related to the reference nominal diameter, DN, used in international standards. The relationship is, typically, as follows:

DN	15	20	25	32	40	50	65	80	100
NPS	1/2	3/4	1	1 1/4	1 1/2	2	2 1/2	3	4

NOTE: For NPS>4, the equivalence is: DN=25 (NPS)

## 4 MARKING

### 4.1 Standard Marking

Each fitting shall be permanently marked to show the following:

- (a) manufacturer's name or trademark.
- (b) material identification, either the ASTM or ASME grade designation.
- (c) schedule number<sup>1</sup> or nominal wall thickness in mm.

<sup>1</sup> Schedule number is a dimensionless number that is widely used as a convenient designation for use in ordering pipe and fittings. It is normally associated with a group of standardized pipe wall thickness. Refer to ASME B36.10 and ASME B36.19 for complete details on pipe schedule numbers.

(d) size — the nominal pipe size (NPS) identification number related to the end connections shall be used.

(e) compliance — see para 4.4 for standard and special fitting marking.

(f) A manufacturer may supplement these mandatory markings with others, including a DN size designation, but confusion with the required marking shall be avoided.

### 4.2 Exceptions

Where the size of the fitting does not permit complete marking, the identification marks may be omitted in reverse of the order presented above.

### 4.3 Depth of Stamping

Where steel stamps are used, care shall be taken so that the marking is not deep enough or sharp enough to cause cracks or to reduce the wall thickness of the fitting below the minimum allowed.

### 4.4 Compliance

**4.4.1 Standard Fittings.** That the fitting was manufactured in conformance with this Standard, including all dimensional requirements, is certified by a prefix "WP" in the material grade designation marking.

**4.4.2 Special Fittings.** That the fitting was manufactured in conformance with this Standard except that dimensional requirements are as agreed between the purchaser and the manufacturer, is certified by a supplementary suffix to the material grade designation marking as follows:

- (a) S9 applies for fittings in accordance with ASTM A 234 and A 403.
- (b) S6 applies for fittings in accordance with ASTM A 420.
- (c) S8 applies for fittings in accordance with ASTM A 815.
- (d) SPLD applies for fittings in accordance with ASTM B 361, B 363, and B 366.

## 5 MATERIAL

Wrought fittings covered by this Standard shall be in accordance with ASTM A 234, A 403, A 420, A 815, B 361, B 363, B 366 or the corresponding standard listed in Section II of the ASME Boiler and Pressure Vessel Code. The term *wrought* denotes fittings made of pipe, tubing, plate, or forgings. Fittings made from block forgings may only be supplied subject to

agreement between manufacturer and purchaser. Such fittings need not meet the requirements of section 7.

## 6 FITTINGS DIMENSIONS

### 6.1 General

This Standard provides for a fixed position for the welding ends with reference to either the center line of the fittings or the overall dimensions. Dimensional requirements for these fittings are to be found in Tables 3 through 12 and Tables I1 through I12 of Mandatory Appendix I.

### 6.2 Special Dimensions

**6.2.1 Fatigue Loading.** For applications where fatigue loading is a concern, required minimum dimensions shall be furnished by the purchaser.

**6.2.2 Bore Diameter.** Bore diameters, away from the ends, are not specified. If special flow path requirements are needed, the bore dimensions shall be specified by the purchaser.

**6.2.3 Stub Ends.** Service conditions and joint construction often dictate stub end length requirements. Therefore, the purchaser must specify long or short pattern fitting when ordering. (See General Note (c) in Tables 10 and I9.)

## 7 SURFACE CONTOURS

Where adjacent openings in fittings are not in parallel planes, they shall be joined by a circular arc on the external surfaces. The arc may be terminated in tangents.

## 8 END PREPARATION

Unless otherwise specified, the details of the welding end preparation shall be in accordance with Table 1. Transitions from the welding bevel to outside surface of the fitting and from the root face to the inside surface of the fitting lying within the maximum envelope shown in Fig. 1 are at the manufacturer's option except as covered in Note (5) of Fig. 1 or unless otherwise specifically ordered.

## 9 DESIGN PROOF TEST

### 9.1 Required Tests

Proof tests shall be made as set forth in this Standard when the manufacturer chooses proof testing to qualify the fitting design. Unless otherwise agreed upon between manufacturer and purchaser, the proof test shall be one based on the computed bursting pressure of the fitting and its connecting piping.

### 9.2 Test Assembly

**9.2.1 Representative Components.** Fittings that are representative of production and selected for test shall be identified as to material, grade, and lot, including heat treatment. They shall be inspected for dimensional compliance to this Standard.

**9.2.2 Other Components.** Straight seamless or welded pipe sections whose calculated bursting strength is at least as great as the proof test pressure as calculated in para. 9.3 shall be welded to each end of the fitting to be tested. Any internal misalignment greater than 1.5 mm (0.06 in.) shall be reduced by taper boring at a slope not over 1:3. Length of pipe sections for closures shall be as follows.

(a) Minimum length of pipe shall be one pipe O.D. for NPS 14 (DN 350) and smaller.

(b) Minimum length of pipe shall be one-half pipe O.D. for NPS greater than 14 (DN 350).

### 9.3 Test Procedure

Test fluid shall be water or other liquid used for hydrostatic testing. Hydrostatic pressure shall be applied to the assembly. The test is successful if the assembly withstands, without rupture, 105% of the computed proof test pressure defined below.

$$P = \frac{2St}{D}$$

where

$D$  = specified outside diameter of pipe

$P$  = computed minimum proof test pressure for fitting

$S$  = actual tensile strength of the test fitting, determined on a specimen representative of the test fitting, which shall meet the tensile strength requirements of the applicable material of section 5.

FACTORY-MADE WROUGHT BUTTWELDING FITTINGS

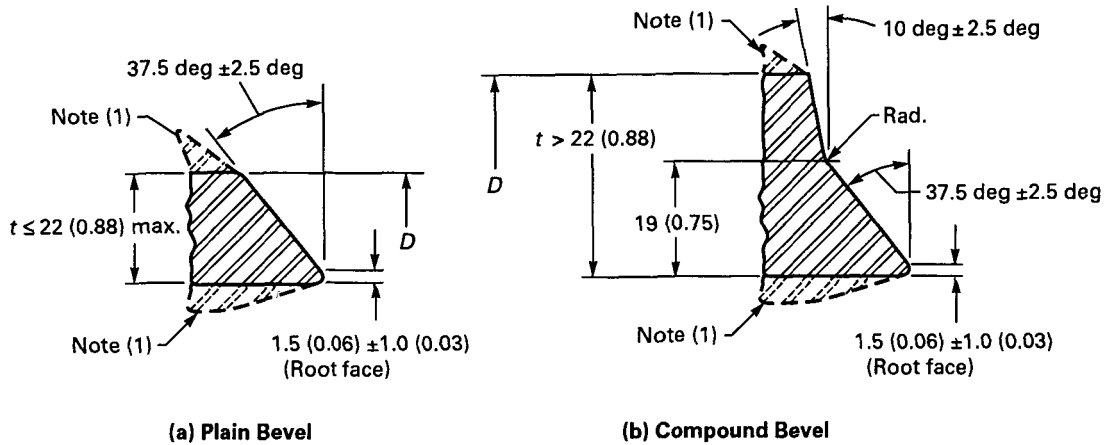

TABLE 1 WELDING BEVELS AND ROOT FACE

Nominal Wall Thickness, <i>t</i>	End Preparation
Less than <i>x</i> [Note (2)]	Cut square or slightly chamfer, at manufacturer's option. (Not illustrated.)
<i>x</i> to 22 (0.88) included	Plain bevel as in sketch (a) above.
More than 22 (0.88)	Compound bevel as in sketch (b) above.

GENERAL NOTES:

- (a) Dimensions in parentheses are in inches.
- (b) Other dimensions are in millimeters.

NOTES:

- (1) See section 8 and Fig. 1 for transition contours.
- (2) *x* = 5 (0.19) for carbon steel or ferritic alloy steel and 3 (0.12) for austenitic alloy steel.

*t* = nominal pipe wall thickness of the pipe that the fitting marking identifies

NOTE: Any dimensionally consistent system of units may be used.

9.4 Applicability of Test Results

It is not necessary to conduct an individual test of fittings with all combinations of sizes, wall thicknesses, and materials. A successful proof test on one representative fitting may represent others to the extent described in this Standard.

**9.4.1 Size Range.** One test fitting may be used to qualify similarly proportioned fittings with a size range from one-half to twice that for the tested fitting. The test of a non-reducing fitting qualifies reducing

fittings of the same pattern. The test of a reducing fitting qualifies reductions to smaller sizes.

**9.4.2 Thickness Range.** One test fitting may be used to qualify similarly proportioned fittings with *t/D* ranges from one-half to three times that for the tested fitting.

**9.4.3 Material Grades.** The pressure retaining capacity of a geometrically identical fitting made of various grades of steel will be directly proportional to the tensile properties of the various grades; see para 2.1. Therefore, it is necessary to test only a single material grade in a representative fitting to prove the design of the fitting.

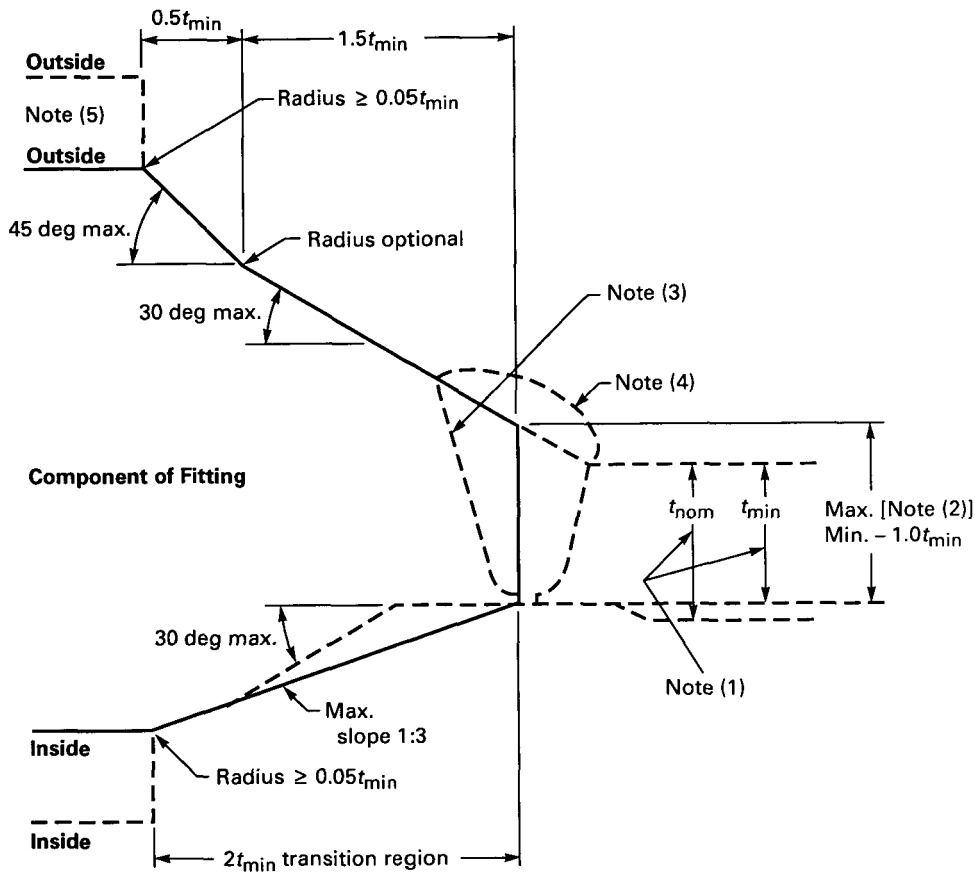

NOTES:

- (1) The value of  $t_{min}$  is whichever of the following is applicable:
  - (a) the minimum ordered wall thickness of the pipe;
  - (b) 0.875 times the nominal wall thickness of pipe ordered to a pipe schedule wall thickness that has an undertolerance of 12.5%.
- (2) The maximum thickness at the end of the component is:
  - (a) the greater of [ $t_{min} + 4\text{mm}$  (0.16 in.)] or  $1.15t_{min}$  when ordered on a minimum wall basis;
  - (b) the greater of [ $t_{min} + 4\text{mm}$  (0.16 in.)] or  $1.10t_{nom}$  when ordered on a nominal wall basis.
- (3) Weld bevel shown is for illustration only.
- (4) The weld reinforcement permitted by applicable code may lie outside the maximum envelope.
- (5) Where transitions using maximum slope do not intersect outside surface within the transition region, as shown by phantom outline, maximum slopes shown shall be used. Alternately, radii lying within the envelope may be used.

FIG. 1 MAXIMUM ENVELOPE FOR WELDING END TRANSITIONS

10 PRODUCTION TESTS

Hydrostatic testing of wrought fittings is not required by this Standard. All fittings shall be capable of withstanding, without leakage or impairment of serviceability, a hydrostatic test pressure required by the applicable piping code for seamless pipe of material equivalent to the fitting material and of the size and wall thickness the fitting marking identifies.

11 TOLERANCES

Tolerances for fittings are shown in Tables 2 and I1, and apply to the nominal dimensions given in Tables 3 through 12 and Tables I2 through I11. Where given in the tables, the minimum and maximum dimensions are based on these tolerances. The listings with decimals do not imply precision measurement such as use of vernier, micrometer, electronic readout equipment, etc.

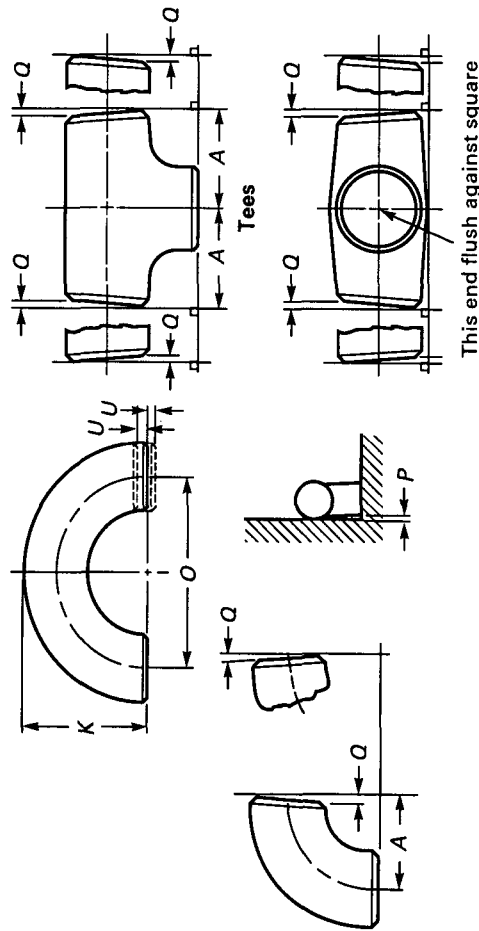

TABLE 2 ILLUSTRATION

TABLE 2 TOLERANCES

All Fittings				Center-to-End Dimensions of 90 Deg and 45 Deg Elbows and Tees, A, B, C, M	Overall Length of Reducers and Lap Joint Stub Ends, F, H	Overall Length of Caps, E	180 Deg Returns		
Nominal Pipe Size (NPS)	(DN)	Outside Diameter at Bevel, D [Notes (1), and (2)]	Inside Diameter at End [Notes (1),(3), and (4)]				Wall Thickness, t [Note (3)]	Center-to-Center Dimension, O	Back-to-Face Dimension, K
1/2 to 2 1/2	15-65	+1.6-0.8	0.8		2	3	6	6	1
3 to 3 1/2	80-90	+1.6	1.6	Not	2	3	6	6	1
4	100	+1.6	1.6	Less	2	3	6	6	1
5 to 8	125-200	+2.4-1.6	1.6	Than	2	6	6	6	1
10 to 18	250-450	+4.0-3.2	3.2	87.5%	2	6	10	6	2
20 to 24	500-600	+6.4-4.8	4.8	of	2	6	10	6	2
26 to 30	650-750	+6.4-4.8	4.8	Nominal	3	10	...	...	...
37 to 48	800-1200	+6.4-4.8	4.8	Thickness	5	10	...	...	...

Lap Joint Stub Ends					Angularity Tolerances				
Nominal Pipe Size (NPS)	(DN)	Outside Diameter of Lap, G	Fillet Radius of Lap, R	Outside Diameter of Barrel	Lap Thickness	Nominal Pipe Size (NPS)	(DN)	Off Angle, Q	Off Plane, P
1/2 to 2 1/2	15-65	+0-1	+0-1		+1.6-0	1/2 to 4	15-100	1	2
3 to 3 1/2	80-900	+0-1	+0-1	See	+1.6-0	5 to 8	125-200	2	4
4	100	+0-1	+0-2	Table 10	+1.6-0	10 to 12	250-300	2	5
5 to 8	125-200	+0-1	+0-2	For	+1.6-0	14 to 16	350-400	3	6
10 to 18	250-450	+0-2	+0-2	Limiting	+3.2-0	18 to 24	450-600	4	10
20 to 24	500-600	+0-2	+0-2	Dimensions	+3.2-0	26 to 30	650-750	5	10
26 to 30	650-750	...	...		...	32 to 42	800-1050	5	13
37 to 48	800-1200	...	...		...	44-48	1100-1200	5	19

GENERAL NOTES:

- (a) For reference, see Table 2 Illustration beginning on page 6.
- (b) All dimensions are in millimeters.
- (c) Tolerances are equal plus and minus except as noted.

NOTES:

- (1) Out-of-round is the sum of absolute values of plus and minus tolerances.
- (2) This tolerance may not apply in localized areas of formed fittings where increased wall thickness is required to meet design requirements of para. 2.2.
- (3) The inside diameter and the nominal wall thicknesses at ends are to be specified by the purchaser.
- (4) Unless otherwise specified by the purchaser, these tolerances apply to the nominal inside diameter, which equals the difference between the nominal outside diameter and twice the nominal wall thickness.



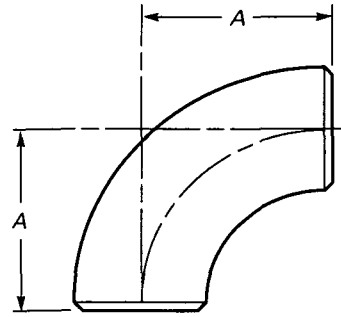
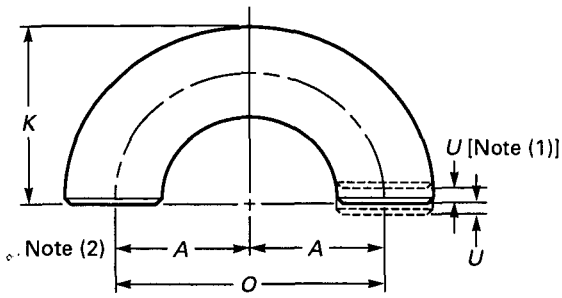

**TABLE 5 DIMENSIONS OF LONG RADIUS RETURNS**

Nominal Pipe Size (NPS)	DN	Outside Diameter at Bevel	Center-to-Center, D	Back-to-Face, K
1/2	15	21.3	76	48
3/4	20 [Note (3)]	26.7	76	51
1	25	33.4	76	56
1 1/4	32	42.2	95	70
1 1/2	40	48.3	114	83
2	50	60.3	152	106
2 1/2	65	73.0	190	132
3	80	88.9	229	159
3 1/2	90	101.6	267	184
4	100	114.3	305	210
5	125	141.3	381	262
6	150	168.3	457	313
8	200	219.1	610	414
10	250	273.0	762	518
12	300	323.8	914	619
14	350	355.6	1067	711
16	400	406.4	1219	813
18	450	457	1372	914
20	500	508	1524	1016
22	550	559	1676	1118
24	600	610	1829	1219

**TABLE 6 DIMENSIONS OF SHORT RADIUS ELBOWS**

Nominal Pipe Size (NPS)	DN	Outside Diameter at Bevel	Center-to-End, A
1	25	33.4	25
1 1/4	32	42.2	32
1 1/2	40	48.3	38
2	50	60.3	51
2 1/2	65	73.0	64
3	80	88.9	76
3 1/2	90	101.6	89
4	100	114.3	102
5	125	141.3	127
6	150	168.3	152
8	200	219.1	203
10	250	273.0	254
12	300	323.8	305
14	350	355.6	356
16	400	406.4	406
18	450	457	457
20	500	508	508
22	550	559	559
24	600	610	610

GENERAL NOTE: All dimensions are in millimeters.

GENERAL NOTE: All dimensions are in millimeters.

NOTES:

- (1) See Table 2 for tolerance for alignment of ends U.
- (2) Dimension A is equal to one-half of dimension O.
- (3) O and K dimensions of 57 mm and 43 mm, respectively, may be furnished for NPS 3/4 (DN 20) at the manufacturer's option.

FACTORY-MADE WROUGHT BUTTWELDING FITTINGS

ASME B16.9-2001

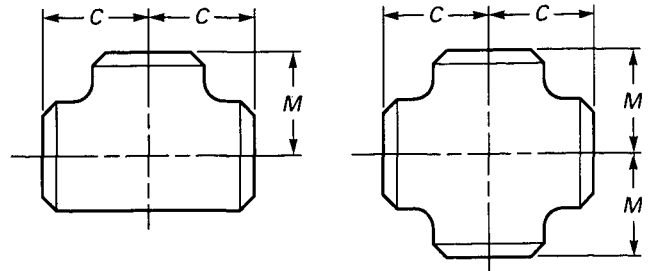
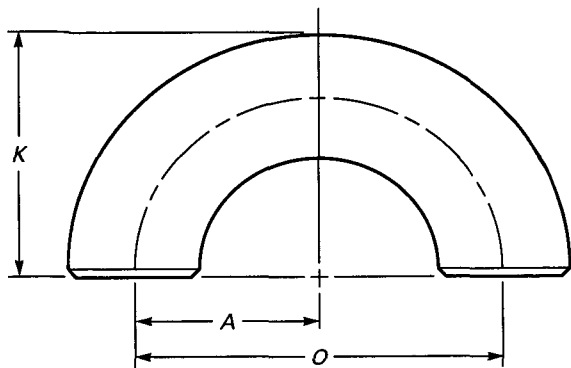

**TABLE 7 DIMENSIONS OF SHORT RADIUS 180 deg RETURNS**

Nominal Pipe Size (NPS)	DN	Outside Diameter at Bevel	Center-to-Center, O	Back-to-Face, K
1	25	33.4	51	41
1 1/4	32	42.2	64	52
1 1/2	40	48.3	76	62
2	50	60.3	102	81
2 1/2	65	73.0	127	100
3	80	88.9	152	121
3 1/2	90	101.6	178	140
4	100	114.3	203	159
5	125	141.3	254	197
6	150	168.3	305	237
8	200	219.1	406	313
10	250	273.0	508	391
12	300	323.8	610	467
14	350	355.6	711	533
16	400	406.4	813	610
18	450	457	914	686
20	500	508	1016	762
22	550	559	1118	838
24	600	610	1219	914

GENERAL NOTES:

- (a) All dimensions are in millimeters.
- (b) Dimension A is equal to one-half of dimension O.

**TABLE 8 DIMENSIONS OF STRAIGHT TEES AND CROSSES**

Nominal Pipe Size (NPS)	DN	Outside Diameter at Bevel	Center-to-End	
			Run, C	Outlet, M [Notes (1) and (2)]
1/2	15	21.3	25	25
3/4	20	26.7	29	29
1	25	33.4	38	38
1 1/4	32	42.2	48	48
1 1/2	40	48.3	57	57
2	50	60.3	64	64
2 1/2	65	73.0	76	76
3	80	88.9	86	86
3 1/2	90	101.6	95	95
4	100	114.3	105	105
5	125	141.3	124	124
6	150	168.3	143	143
8	200	219.1	178	178
10	250	273.0	216	216
12	300	323.8	254	254
14	350	355.6	279	279
16	400	406.4	305	305
18	450	457	343	343
20	500	508	381	381
22	550	559	419	419
24	600	610	432	432
26	650	660	495	495
28	700	711	521	521
30	750	762	559	559
32	800	813	597	597
34	850	864	635	635
36	900	914	673	673
38	950	965	711	711
40	1000	1016	749	749
42	1050	1067	762	711
44	1100	1118	813	762
46	1150	1168	851	800
48	1200	1219	889	838

GENERAL NOTE: All dimensions are in millimeters.

NOTES:

- (1) Outlet dimension M for NPS 26 (DN 650) and larger is recommended but not required.
- (2) Dimensions applicable to crosses NPS 24 (DN 600) and smaller.

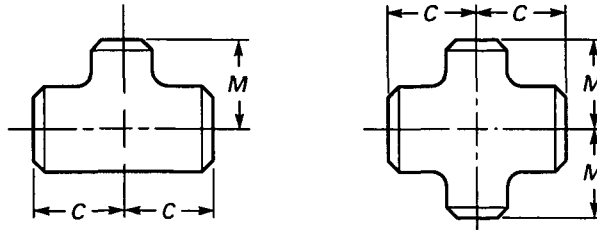

**TABLE 9 DIMENSIONS OF REDUCING OUTLET TEES AND REDUCING OUTLET CROSSES**

Nominal Pipe Size (NPS)	DN	Outside Diameter at Bevel		Center-to-End	
		Run	Outlet	Run, C	Outlet, M [Note (1)]
1/2 x 1/2 x 3/8	15 x 15 x 10	21.3	17.3	25	25
1/2 x 1/2 x 1/4	15 x 15 x 8	21.3	13.7	25	25
3/4 x 3/4 x 1/2	20 x 20 x 15	26.7	21.3	29	29
3/4 x 3/4 x 3/8	20 x 20 x 10	26.7	17.3	29	29
1 x 1 x 3/4	25 x 25 x 20	33.4	26.7	38	38
1 x 1 x 1/2	25 x 25 x 15	33.4	21.3	38	38
1 1/4 x 1 1/4 x 1	32 x 32 x 25	42.2	33.4	48	48
1 1/4 x 1 1/4 x 3/4	32 x 32 x 20	42.2	26.7	48	48
1 1/4 x 1 1/4 x 1/2	32 x 32 x 15	42.2	21.3	48	48
1 1/2 x 1 1/2 x 1 1/4	40 x 40 x 32	48.3	42.2	57	57
1 1/2 x 1 1/2 x 1	40 x 40 x 25	48.3	33.4	57	57
1 1/2 x 1 1/2 x 3/4	40 x 40 x 20	48.3	26.7	57	57
1 1/2 x 1 1/2 x 1/2	40 x 40 x 15	48.3	21.3	57	57
2 x 2 x 1 1/2	50 x 50 x 40	60.3	48.3	64	60
2 x 2 x 1 1/4	50 x 50 x 32	60.3	42.2	64	57
2 x 2 x 1	50 x 50 x 25	60.3	33.4	64	51
2 x 2 x 3/4	50 x 50 x 20	60.3	26.7	64	44
2 1/2 x 2 1/2 x 2	65 x 65 x 50	73.0	60.3	76	70
2 1/2 x 2 1/2 x 1 1/2	65 x 65 x 40	73.0	48.3	76	67
2 1/2 x 2 1/2 x 1 1/4	65 x 65 x 32	73.0	42.2	76	64
2 1/2 x 2 1/2 x 1	65 x 65 x 25	73.0	33.4	76	57
3 x 3 x 2 1/2	80 x 80 x 65	88.9	73.0	86	83
3 x 3 x 2	80 x 80 x 50	88.9	60.3	86	76
3 x 3 x 1 1/2	80 x 80 x 40	88.9	48.3	86	73
3 x 3 x 1 1/4	80 x 80 x 32	88.9	42.2	86	70
3 1/2 x 3 1/2 x 3	90 x 90 x 80	101.6	88.9	95	92
3 1/2 x 3 1/2 x 2 1/2	90 x 90 x 65	101.6	73.0	95	89
3 1/2 x 3 1/2 x 2	90 x 90 x 50	101.6	60.3	95	83
3 1/2 x 3 1/2 x 1 1/2	90 x 90 x 40	101.6	48.3	95	79
4 x 4 x 3 1/2	100 x 100 x 90	114.3	101.6	105	102
4 x 4 x 3	100 x 100 x 80	114.3	88.9	105	98
4 x 4 x 2 1/2	100 x 100 x 65	113.3	73.0	105	95
4 x 4 x 2	100 x 100 x 50	114.3	60.3	105	89
4 x 4 x 1 1/2	100 x 100 x 40	114.3	48.3	105	86
5 x 5 x 4	125 x 125 x 100	141.3	114.3	125	117
5 x 5 x 3 1/2	125 x 125 x 90	141.3	101.6	124	114
5 x 5 x 3	125 x 125 x 80	141.3	88.9	124	111
5 x 5 x 2 1/2	125 x 125 x 65	141.3	73.0	124	108
5 x 5 x 2	125 x 125 x 50	141.3	60.3	124	105

(continued)

**TABLE 9 DIMENSIONS OF REDUCING OUTLET TEES AND REDUCING OUTLET CROSSES (CONT'D)**

Nominal Pipe Size (NPS)	DN	Outside Diameter at Bevel		Center-to-End	
		Run	Outlet	Run, C	Outlet, <i>M</i> [Note (1)]
6 × 6 × 5	150 × 150 × 125	168.3	141.3	143	137
6 × 6 × 4	150 × 150 × 100	168.3	114.3	143	130
6 × 6 × 3½	150 × 150 × 90	168.3	101.6	143	127
6 × 6 × 3	150 × 150 × 80	168.3	88.9	143	124
6 × 6 × 2½	150 × 150 × 65	168.3	73.0	143	121
8 × 8 × 6	200 × 200 × 150	219.1	168.3	178	168
8 × 8 × 5	200 × 200 × 125	219.1	141.3	178	162
8 × 8 × 4	200 × 200 × 100	219.1	114.3	178	156
8 × 8 × 3½	200 × 200 × 90	219.1	101.6	178	152
10 × 10 × 8	250 × 250 × 200	273.0	219.1	216	203
10 × 10 × 6	250 × 250 × 150	273.0	168.3	216	194
10 × 10 × 5	250 × 250 × 125	273.0	141.3	216	191
10 × 10 × 4	250 × 250 × 100	273.0	114.3	216	184
12 × 12 × 10	300 × 300 × 250	323.8	273.0	254	241
12 × 12 × 8	300 × 300 × 200	323.8	219.1	254	229
12 × 12 × 6	300 × 300 × 150	323.8	168.3	254	219
12 × 12 × 5	300 × 300 × 125	323.8	141.3	254	216
14 × 14 × 12	350 × 350 × 300	355.6	323.8	279	270
14 × 14 × 10	350 × 350 × 250	355.6	273.0	279	257
14 × 14 × 8	350 × 350 × 200	355.6	219.1	279	248
14 × 14 × 6	350 × 350 × 150	355.6	168.3	279	238
16 × 16 × 14	400 × 400 × 350	406.4	355.6	305	305
16 × 16 × 12	400 × 400 × 300	406.4	323.8	305	295
16 × 16 × 10	400 × 400 × 250	406.4	273.0	305	283
16 × 16 × 8	400 × 400 × 200	406.4	219.1	305	273
16 × 16 × 6	400 × 400 × 150	406.4	168.3	305	264
18 × 18 × 16	450 × 450 × 400	457	406.4	343	330
18 × 18 × 14	450 × 450 × 350	457	355.6	343	330
18 × 18 × 12	450 × 450 × 300	457	323.8	343	321
18 × 18 × 10	450 × 450 × 250	457	273.0	343	308
18 × 18 × 8	450 × 450 × 200	457	219.1	343	298
20 × 20 × 18	500 × 500 × 450	508	457	381	368
20 × 20 × 16	500 × 500 × 400	508	406.4	381	356
20 × 20 × 14	500 × 500 × 350	508	355.6	381	356
20 × 20 × 12	500 × 500 × 300	508	323.8	381	346
20 × 20 × 10	500 × 500 × 250	508	273.0	381	333
20 × 20 × 8	500 × 500 × 200	508	219.1	381	324
22 × 22 × 20	550 × 550 × 500	559	508	419	406
22 × 22 × 18	550 × 550 × 450	559	457	419	394
22 × 22 × 16	550 × 550 × 400	559	406.4	419	381
22 × 22 × 14	550 × 550 × 350	559	355.6	419	381
22 × 22 × 12	550 × 550 × 300	559	323.8	419	371
22 × 22 × 10	550 × 550 × 250	559	273.0	419	359

(continued)

**TABLE 9 DIMENSIONS OF REDUCING OUTLET TEES AND REDUCING OUTLET CROSSES  
(CONT'D)**

Nominal Pipe Size (NPS)	DN	Outside Diameter at Bevel		Center-to-End	
		Run	Outlet	Run, C	Outlet, <i>M</i> [Note (1)]
24 × 24 × 22	600 × 600 × 550	610	559	432	432
24 × 24 × 20	600 × 600 × 500	610	508	432	432
24 × 24 × 18	600 × 600 × 450	610	457	432	419
24 × 24 × 16	600 × 600 × 400	610	406.4	432	406
24 × 24 × 14	600 × 600 × 350	610	355.6	432	406
24 × 24 × 12	600 × 600 × 300	610	323.8	432	397
24 × 24 × 10	600 × 600 × 250	610	273.0	432	384
26 × 26 × 24	650 × 650 × 600	660	610	495	483
26 × 26 × 22	650 × 650 × 550	660	559	495	470
26 × 26 × 20	650 × 650 × 500	660	508	495	457
26 × 26 × 18	650 × 650 × 450	660	457	495	444
26 × 26 × 16	650 × 650 × 400	660	406.4	495	432
26 × 26 × 14	650 × 650 × 350	660	355.6	495	432
26 × 26 × 12	650 × 650 × 300	660	323.8	495	422
28 × 28 × 26	700 × 700 × 650	711	660	521	521
28 × 28 × 24	700 × 700 × 600	711	610	521	508
28 × 28 × 22	700 × 700 × 550	711	559	521	495
28 × 28 × 20	700 × 700 × 500	711	508	521	483
28 × 28 × 18	700 × 700 × 450	711	457	521	470
28 × 28 × 16	700 × 700 × 400	711	406.4	521	457
28 × 28 × 14	700 × 700 × 350	711	355.6	521	457
28 × 28 × 12	700 × 700 × 300	711	323.8	521	448
30 × 30 × 28	750 × 750 × 700	762	711	559	546
30 × 30 × 26	750 × 750 × 650	762	660	559	546
30 × 30 × 24	750 × 750 × 600	762	610	559	533
30 × 30 × 22	750 × 750 × 550	762	559	559	521
30 × 30 × 20	750 × 750 × 500	762	508	559	508
30 × 30 × 18	750 × 750 × 450	762	457	559	495
30 × 30 × 16	750 × 750 × 400	762	406.4	559	483
30 × 30 × 14	750 × 750 × 350	762	355.6	559	483
30 × 30 × 12	750 × 750 × 300	762	323.8	559	473
30 × 30 × 10	750 × 750 × 250	762	273.0	559	460
32 × 32 × 30	800 × 800 × 750	813	762	597	584
32 × 32 × 28	800 × 800 × 700	813	711	597	572
32 × 32 × 26	800 × 800 × 650	813	660	597	572
32 × 32 × 24	800 × 800 × 600	813	610	597	559
32 × 32 × 22	800 × 800 × 550	813	559	597	546
32 × 32 × 20	800 × 800 × 500	813	508	597	533
32 × 32 × 18	800 × 800 × 450	813	457	597	521
32 × 32 × 16	800 × 800 × 400	813	406.4	597	508
32 × 32 × 14	800 × 800 × 350	813	355.6	597	508
34 × 34 × 32	850 × 850 × 800	864	813	635	622
34 × 34 × 30	850 × 850 × 750	864	762	635	610
34 × 34 × 28	850 × 850 × 700	864	711	635	597
34 × 34 × 26	850 × 850 × 650	864	600	635	597
34 × 34 × 24	850 × 850 × 600	864	610	635	584
34 × 34 × 22	850 × 850 × 550	864	559	635	572
34 × 34 × 20	850 × 850 × 500	864	508	635	559

(continued)

**TABLE 9 DIMENSIONS OF REDUCING OUTLET TEES AND REDUCING OUTLET CROSSES (CONT'D)**

Nominal Pipe Size (NPS)	DN	Outside Diameter at Bevel		Center-to-End	
		Run	Outlet	Run, C	Outlet, M [Note (1)]
34 × 34 × 18	850 × 850 × 450	864	457	635	546
34 × 34 × 16	850 × 850 × 400	864	406.4	635	533
36 × 36 × 34	900 × 900 × 850	914	864	673	660
36 × 36 × 32	900 × 900 × 800	914	813	673	648
36 × 36 × 30	900 × 900 × 750	914	762	673	635
36 × 36 × 28	900 × 900 × 700	914	711	673	622
36 × 36 × 26	900 × 900 × 650	914	660	673	622
36 × 36 × 24	900 × 900 × 600	914	610	673	610
36 × 36 × 22	900 × 900 × 550	914	559	673	597
36 × 36 × 20	900 × 900 × 500	914	508	673	584
36 × 36 × 18	900 × 900 × 450	914	457	673	572
36 × 36 × 16	900 × 900 × 400	914	406.4	673	559
38 × 38 × 36	950 × 950 × 900	965	914	711	711
38 × 38 × 34	950 × 950 × 850	965	864	711	698
38 × 38 × 32	950 × 950 × 800	965	813	711	686
38 × 38 × 30	950 × 950 × 750	965	762	711	673
38 × 38 × 28	950 × 950 × 700	965	711	711	648
38 × 38 × 26	950 × 950 × 650	965	660	711	648
38 × 38 × 24	950 × 950 × 600	965	610	711	635
38 × 38 × 22	950 × 950 × 550	965	559	711	622
38 × 38 × 20	950 × 950 × 500	965	508	711	610
38 × 38 × 18	950 × 950 × 450	965	457	711	597
40 × 40 × 38	1000 × 1000 × 950	1016	965	749	749
40 × 40 × 36	1000 × 1000 × 900	1016	914	749	737
40 × 40 × 34	1000 × 1000 × 850	1016	864	749	724
40 × 40 × 32	1000 × 1000 × 800	1016	813	749	711
40 × 40 × 30	1000 × 1000 × 750	1016	762	749	698
40 × 40 × 28	1000 × 1000 × 700	1016	711	749	673
40 × 40 × 26	1000 × 1000 × 650	1016	660	749	673
40 × 40 × 24	1000 × 1000 × 600	1016	610	749	660
40 × 40 × 22	1000 × 1000 × 550	1016	559	749	648
40 × 40 × 20	1000 × 1000 × 500	1016	508	749	635
40 × 40 × 18	1000 × 1000 × 450	1016	457	749	622
42 × 42 × 40	1050 × 1050 × 1000	1067	1016	762	711
42 × 42 × 38	1050 × 1050 × 950	1067	968	762	711
42 × 42 × 36	1050 × 1050 × 900	1067	914	762	711
42 × 42 × 34	1050 × 1050 × 850	1067	864	762	711
42 × 42 × 32	1050 × 1050 × 800	1067	813	762	711
42 × 42 × 30	1050 × 1050 × 750	1067	762	762	711
42 × 42 × 28	1050 × 1050 × 700	1067	711	762	698
42 × 42 × 26	1050 × 1050 × 650	1067	660	762	698
42 × 42 × 24	1050 × 1050 × 600	1067	610	762	660
42 × 42 × 22	1050 × 1050 × 550	1067	559	762	660
42 × 42 × 20	1050 × 1050 × 500	1067	508	762	660
42 × 42 × 18	1050 × 1050 × 450	1067	457	762	648
42 × 42 × 16	1050 × 1050 × 400	1067	406.4	762	635
44 × 44 × 42	1100 × 1100 × 1050	1118	1067	813	762
44 × 44 × 40	1100 × 1100 × 1000	1118	1016	813	749

(continued)

**TABLE 9 DIMENSIONS OF REDUCING OUTLET TEES AND REDUCING OUTLET CROSSES  
(CONT'D)**

Nominal Pipe Size (NPS)	DN	Outside Diameter at Bevel		Center-to-End	
		Run	Outlet	Run, C	Outlet, <i>M</i> [Note (1)]
44 × 44 × 38	1100 × 1100 × 950	1118	965	813	737
44 × 44 × 36	1100 × 1100 × 900	1118	914	813	724
44 × 44 × 34	1100 × 1100 × 850	1118	864	813	724
44 × 44 × 32	1100 × 1100 × 800	1118	813	813	711
44 × 44 × 30	1100 × 1100 × 750	1118	762	813	711
44 × 44 × 28	1100 × 1100 × 700	1118	711	813	698
44 × 44 × 26	1100 × 1100 × 650	1118	660	813	698
44 × 44 × 24	1100 × 1100 × 600	1118	610	813	698
44 × 44 × 22	1100 × 1100 × 550	1118	559	813	686
44 × 44 × 20	1100 × 1100 × 500	1118	508	813	686
46 × 46 × 44	1150 × 1150 × 1100	1168	1118	851	800
46 × 46 × 42	1150 × 1150 × 1050	1168	1067	851	787
46 × 46 × 40	1150 × 1150 × 1000	1168	1016	851	775
46 × 46 × 38	1150 × 1150 × 950	1168	965	851	762
46 × 46 × 36	1150 × 1150 × 900	1168	914	851	762
46 × 46 × 34	1150 × 1150 × 850	1168	864	851	749
46 × 46 × 32	1150 × 1150 × 800	1168	813	851	749
46 × 46 × 30	1150 × 1150 × 750	1168	762	851	737
46 × 46 × 28	1150 × 1150 × 700	1168	711	851	737
46 × 46 × 26	1150 × 1150 × 650	1168	660	851	737
46 × 46 × 24	1150 × 1150 × 600	1168	610	851	724
46 × 46 × 22	1150 × 1150 × 550	1168	559	851	724
48 × 48 × 46	1200 × 1200 × 1150	1219	1168	889	838
48 × 48 × 44	1200 × 1200 × 1100	1219	1118	889	838
48 × 48 × 42	1200 × 1200 × 1050	1219	1067	889	813
48 × 48 × 40	1200 × 1200 × 1000	1219	1016	889	813
48 × 48 × 38	1200 × 1200 × 950	1219	965	889	813
48 × 48 × 36	1200 × 1200 × 900	1219	914	889	787
48 × 48 × 34	1200 × 1200 × 850	1219	864	889	787
48 × 48 × 32	1200 × 1200 × 800	1219	813	889	787
48 × 48 × 30	1200 × 1200 × 750	1219	762	889	762
48 × 48 × 28	1200 × 1200 × 700	1219	711	889	762
48 × 48 × 26	1200 × 1200 × 650	1219	660	889	762
48 × 48 × 24	1200 × 1200 × 600	1219	610	889	737
48 × 48 × 22	1200 × 1200 × 550	1219	559	889	737

GENERAL NOTE: All dimensions are in millimeters.

NOTE:

(1) Outlet dimension *M* for run sizes NPS 14 (DN 350) and larger is recommended but not required.

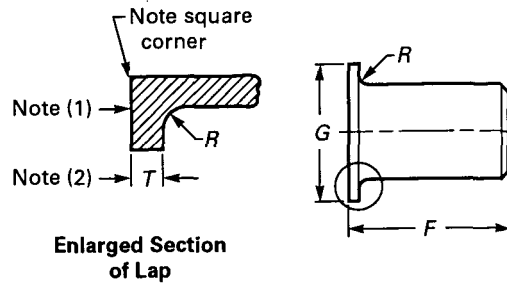

**TABLE 10 DIMENSIONS OF LAP JOINT STUB ENDS**

Nominal Pipe Size (NPS)	DN	Outside Diameter of Barrel		Long Pattern Length, <i>F</i> [Notes (3), (4)]	Short Pattern Length, <i>F</i> [Notes (3), (4)]	Radius of Fillet, <i>R</i> [Note (5)]	Diameter of Lap, <i>G</i> [Note (6)]
		Max.	Min.				
1/2	15	22.8	20.5	76	51	3	35
3/4	20	28.1	25.9	76	51	3	43
1	25	35.0	32.6	102	51	3	51
1 1/4	32	43.6	41.4	102	51	5	64
1 1/2	40	49.9	47.5	102	51	6	73
2	50	62.4	59.5	152	64	8	92
2 1/2	65	75.3	72.2	152	64	8	106
3	80	91.3	88.1	152	64	10	127
3 1/2	90	104.0	100.8	152	76	10	140
4	100	116.7	113.5	152	76	11	157
5	125	144.3	140.5	203	76	11	185
6	150	171.3	167.5	203	89	13	218
8	200	222.1	218.3	203	102	13	270
10	250	277.2	272.3	254	127	13	324
12	300	328.0	323.1	254	152	13	381
14	350	359.9	354.8	305	152	13	413
16	400	411.0	405.6	305	152	13	470
18	450	462	456	305	152	13	533
20	500	514	507	305	152	13	584
22	550	565	558	305	152	13	641
24	600	616	609	305	152	13	692

**GENERAL NOTES:**

- (a) All dimensions are in millimeters.
- (b) See Table 2 for tolerances.
- (c) Service conditions and joint construction often dictate stub end length requirements. Therefore, the purchaser must specify long or short pattern fitting when ordering.

**NOTES:**

- (1) Gasket face finish shall be in accordance with ASME B16.5 for raised face flanges.
- (2) The lap thickness *T* shall not be less than nominal pipe wall thickness. See Table 2 for maximum tolerance.
- (3) When short pattern stub ends are used with larger flanges in Classes 300 and 600, (PN50 & PN110) and with most sizes in Classes 900 (PN150) and higher, and when long pattern stub ends are used with larger flanges in Classes 1500 and 2500, (PN260 AND PN420) it may be necessary to increase the length of the stub ends in order to avoid covering the weld with the flange. Such increases in length shall be a matter of agreement between the manufacturer and purchaser.
- (4) When special facings such as tongue and groove, male and female, etc., are employed, additional lap thickness must be provided and such additional thickness shall be in addition to (not included in) the basic length *F*.
- (5) These dimensions conform to the radius established for lap joint flanges in ASME B16.5, Pipe Flanges and Flanged Fittings.
- (6) This dimension conforms to standard machined facings shown in ASME B16.5. The back face of the lap shall be machined to conform to the surface on which it seats. Where ring joint facings are to be applied, use dimension *K* as given in ASME B16.5.



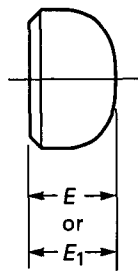

TABLE 11 DIMENSIONS OF CAPS

Nominal Pipe Size (NPS)	DN	Outside Diameter at Bevel	Length, $E$ [Note (1)]	Limiting Wall Thickness for Length, $E$	Length, $E$ [Note (2)]
1/2	15	21.3	25	4.57	25
3/4	20	26.7	25	3.81	25
1	25	33.4	38	4.57	38
1 1/4	32	42.2	38	4.83	38
1 1/2	40	48.3	38	5.08	38
2	50	60.3	38	5.59	44
2 1/2	65	73.0	38	7.11	51
3	80	88.9	51	7.62	64
3 1/2	90	101.6	64	8.13	76
4	100	114.3	64	8.64	76
5	125	141.3	76	9.65	89
6	150	168.3	89	10.92	102
8	200	219.1	102	12.70	127
10	250	273.0	127	12.70	152
12	300	323.8	152	12.70	178
14	350	355.6	165	12.70	191
16	400	406.4	178	12.70	203
18	450	457	203	12.70	229
20	500	508	229	12.70	254
22	550	559	254	12.70	254
24	600	610	267	12.70	305
26	650	660	267	...	...
28	700	711	267	...	...
30	750	762	267	...	...
32	800	813	267	...	...
34	850	864	267	...	...
36	900	914	267	...	...
38	950	965	305	...	...
40	1000	1016	305	...	...
42	1050	1067	305	...	...
44	1100	1118	343	...	...
46	1150	1168	343	...	...
48	1200	1219	343	...	...

## GENERAL NOTES:

- (a) All dimensions are in millimeters.  
 (b) The shape of these caps shall be ellipsoidal and shall conform to the shape requirements as given in the ASME Boiler and Pressure Vessel Code.

## NOTES:

- (1) Length  $E$  applies for thickness not exceeding that given in column "Limiting Wall Thickness for Length  $E$ ."  
 (2) Length  $E_1$  applies for thickness greater than that given in column "Limiting Wall Thickness" for NPS 24 (DN 600) and smaller. For NPS 26 (DN 65) and larger, length  $E_1$  shall be by agreement between manufacturer and purchaser.

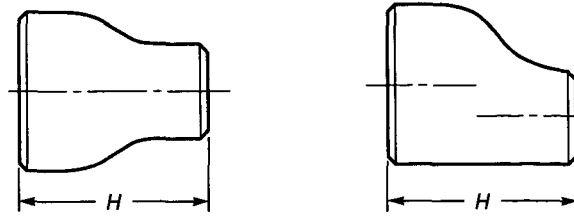

Note (1)

TABLE 12 DIMENSIONS OF REDUCERS

Nominal Pipe Size (NPS)	DN	Outside Diameter at Bevel		End-to-End, H	Nominal Pipe Size (NPS)	DN	Outside Diameter at Bevel		End-to-End, H
		Large End	Small End				Large End	Small End	
3/4 x 1/2	20 x 15	26.7	21.3	38	5 x 4	125 x 100	141.3	114.3	127
3/4 x 3/8	20 x 10	26.7	17.3	38	5 x 3 1/2	125 x 90	141.3	101.6	127
1 x 3/4	25 x 20	33.4	26.7	51	5 x 3	125 x 80	141.3	88.9	127
1 x 1/2	25 x 15	33.4	21.3	51	5 x 2 1/2	125 x 65	141.3	73.0	127
					5 x 2	125 x 50	141.3	60.3	127
1 1/4 x 1	32 x 25	42.2	33.4	51	6 x 5	150 x 125	168.3	141.3	140
1 1/4 x 3/4	32 x 20	42.2	26.7	51	6 x 4	150 x 100	168.3	114.3	140
1 1/4 x 1/2	32 x 15	42.2	21.3	51	6 x 3 1/2	150 x 90	168.3	101.6	140
1 1/2 x 1 1/4	40 x 32	48.3	42.2	64	6 x 3	150 x 80	168.3	88.9	140
1 1/2 x 1	40 x 25	48.3	33.4	64	6 x 2 1/2	150 x 65	168.3	73.0	140
1 1/2 x 3/4	40 x 20	48.3	26.7	64					
1 1/2 x 1/2	40 x 15	48.3	21.3	64	8 x 6	200 x 150	219.1	168.3	152
					8 x 5	200 x 125	219.1	141.3	152
2 x 1 1/2	50 x 40	60.3	48.3	76	8 x 4	200 x 100	219.1	114.3	152
2 x 1 1/4	50 x 32	60.3	42.2	76	8 x 3 1/2	200 x 90	219.1	101.6	152
2 x 1	50 x 25	60.3	33.4	76					
2 x 3/4	50 x 20	60.3	26.7	76	10 x 8	250 x 200	273.0	219.1	178
					10 x 6	250 x 150	273.0	168.3	178
2 1/2 x 2	65 x 50	73.0	60.3	89	10 x 5	250 x 125	273.0	141.3	178
2 1/2 x 1 1/2	65 x 40	73.0	48.3	89	10 x 4	250 x 100	273.0	114.3	178
2 1/2 x 1 1/4	65 x 32	73.0	42.2	89					
2 1/2 x 1	65 x 25	73.0	33.4	89	12 x 10	300 x 250	323.8	273.0	203
					12 x 8	300 x 200	323.8	219.1	203
3 x 2 1/2	80 x 65	88.9	73.0	89	12 x 6	300 x 150	323.8	168.3	203
3 x 2	80 x 50	88.9	60.3	89	12 x 5	300 x 125	323.8	141.3	203
3 x 1 1/2	80 x 40	88.9	48.3	89					
3 x 1 1/4	80 x 32	88.9	42.2	89	14 x 12	350 x 300	355.6	323.8	330
					14 x 10	350 x 250	355.6	273.0	330
3 1/2 x 3	90 x 80	101.6	88.9	102	14 x 8	350 x 200	355.6	219.1	330
3 1/2 x 2 1/2	90 x 65	101.6	73.0	102	14 x 6	350 x 150	355.6	168.3	330
3 1/2 x 2	90 x 50	101.6	60.3	102					
3 1/2 x 1 1/2	90 x 40	101.6	48.3	102	16 x 14	400 x 350	406.4	355.6	356
3 1/2 x 1 1/4	90 x 32	101.6	42.2	102	16 x 12	400 x 300	406.4	323.8	356
					16 x 10	400 x 250	406.4	273.0	356
4 x 3 1/2	100 x 90	114.3	101.6	102	16 x 8	400 x 200	406.4	219.1	356
4 x 3	100 x 80	114.3	88.9	102					
4 x 2 1/2	100 x 65	114.3	73.0	102	18 x 16	450 x 400	457	406.4	381
4 x 2	100 x 50	114.3	60.3	102	18 x 14	450 x 350	457	355.6	381
4 x 1 1/2	100 x 40	114.3	48.3	102	18 x 12	450 x 300	457	323.8	381
					18 x 10	450 x 250	457	273.0	381

(continued)

**TABLE 12 DIMENSIONS OF REDUCERS (CONT'D)**

Nominal Pipe Size (NPS)	DN	Outside Diameter at Bevel		End-to-End, H	Nominal Pipe Size (NPS)	DN	Outside Diameter at Bevel		End-to-End, H
		Large End	Small End				Large End	Small End	
20 x 18	500 x 450	508	457	508	36 x 34	900 x 850	914	864	610
20 x 16	500 x 400	508	406.4	508	36 x 32	900 x 800	914	813	610
20 x 14	500 x 350	508	355.6	508	36 x 30	900 x 750	914	762	610
20 x 12	500 x 300	508	323.8	508	36 x 28	900 x 700	914	660	610
					36 x 26	900 x 650	914	610	610
22 x 20	550 x 500	559	508	508					
22 x 18	550 x 450	559	457	508	38 x 36	950 x 900	965	914	610
22 x 16	550 x 400	559	406.4	508	38 x 34	950 x 850	965	864	610
22 x 14	550 x 350	559	355.4	508	38 x 32	950 x 800	965	813	610
					38 x 30	950 x 750	965	762	610
24 x 22	600 x 550	610	559	508	38 x 28	950 x 700	965	711	610
24 x 20	600 x 500	610	508	508	38 x 26	950 x 650	965	660	610
24 x 18	600 x 450	610	457	508					
24 x 16	600 x 400	610	406.4	508	40 x 38	1000 x 950	1016	965	610
					40 x 36	1000 x 900	1016	914	610
26 x 24	650 x 600	660	610	610	40 x 34	1000 x 850	1016	864	610
26 x 22	650 x 550	660	559	610	40 x 32	1000 x 800	1016	813	610
26 x 20	650 x 500	660	508	610	40 x 30	1000 x 750	1016	762	610
26 x 18	650 x 450	660	457	610					
					42 x 40	1050 x 1000	1067	1016	610
28 x 26	700 x 650	711	660	610	42 x 38	1050 x 950	1067	965	610
28 x 24	700 x 600	711	610	610	42 x 36	1050 x 900	1067	914	610
28 x 22	700 x 550	711	508	610	42 x 34	1050 x 850	1067	864	610
28 x 20	700 x 500	711	457	610	42 x 32	1050 x 800	1067	813	610
					42 x 30	1050 x 750	1067	762	610
30 x 28	750 x 700	762	711	610					
30 x 26	750 x 650	762	660	610	44 x 42	1100 x 1050	1118	1067	610
30 x 24	750 x 600	762	610	610	44 x 40	1100 x 1000	1118	1016	610
30 x 22	750 x 550	762	508	610	44 x 38	1100 x 950	1118	965	610
					44 x 36	1100 x 900	1118	914	610
32 x 30	800 x 750	813	762	610					
32 x 28	800 x 700	813	711	610	46 x 44	1150 x 1100	1168	1118	711
32 x 26	800 x 650	813	660	610	46 x 42	1150 x 1050	1168	1067	711
32 x 24	800 x 600	813	610	610	46 x 40	1150 x 1000	1168	1016	711
					46 x 38	1150 x 950	1168	965	711
34 x 32	850 x 800	864	813	610					
34 x 30	850 x 750	864	762	610	48 x 46	1200 x 1150	1219	1168	711
34 x 28	850 x 700	864	660	610	48 x 44	1200 x 1100	1219	1118	711
34 x 26	850 x 650	864	610	610	48 x 42	1200 x 1050	1219	1067	711
					48 x 40	1200 x 1000	1219	1016	711

GENERAL NOTE: All dimensions are in millimeters.

NOTE:

(1) While the figure illustrates a "bell shaped" reducer, the use of conical reducer is not prohibited.

## **MANDATORY APPENDIX I INCH TABLES**

This Appendix provides tables of the standard inch dimensions for fittings.

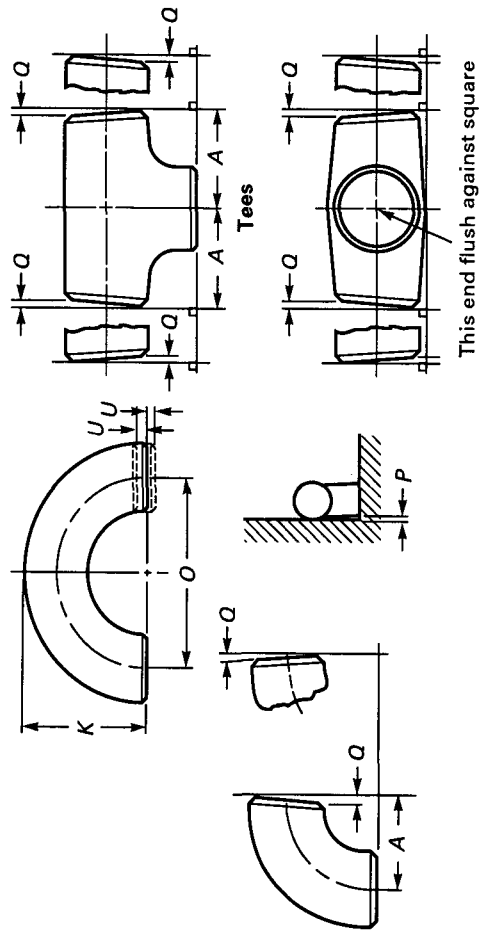

TABLE I1 ILLUSTRATION

TABLE I1 TOLERANCES

Nominal Pipe Size (NPS)	90 Deg Reducers and 45 Deg Lap Joint Elbows and Tees Stub Ends		180 Deg Returns				Lap Joint Stub Ends				Angularity Tolerances		
	Outside Diameter at Bevel [Notes(1) and (2)]	Inside Diameter at End [Notes (1), (3), and (4)]	Center-to-End Dimension, A,B,C,M	Overall Length, FH	Center-to-Center Dimension, O	Back-to-Face Dimension, K	Alignment of Ends, U	Outside Diameter of Lap, G	Fillet Radius of Lap, R	Outside Diameter of Barrel	Lap Thickness, T	Nominal Pipe Size (NPS)	Off Angle, Q
1/2 to 2 1/2	+0.06 0.03	0.03	0.06	0.06	0.12	0.25	0.03	+0	+0	+0.06 0	1/2 to 4	0.03	0.06
3 to 3 1/2	0.06	0.06	0.06	0.06	0.12	0.25	0.03	+0 0.03	+0 0.03	+0.06 0	5 to 8	0.06	0.12
4	0.06	0.06	0.06	0.06	0.12	0.25	0.03	+0 0.03	+0 0.06	+0.06 0	10 to 12	0.09	0.19
5 to 8	+0.09 0.06	0.06	0.06	0.06	0.25	0.25	0.03	+0 0.03	+0 0.06	+0.06 0	14 to 16	0.09	0.25
10 to 18	+0.16 0.12	0.12	0.09	0.09	0.25	0.25	0.06	+0 0.06	+0 0.06	+0.12 0	18 to 24	0.12	0.38
20 to 24	+0.25 0.19	0.19	0.09	0.09	0.25	0.25	0.06	+0 0.06	+0 0.06	+0.12 0	26 to 30	0.19	0.38
26 to 30	+0.25 0.19	0.19	0.12	0.19	0.38	...	...	...	...	...	32 to 42	0.19	0.50
32 to 48	+0.25 0.19	0.19	0.19	0.19	0.38	...	...	...	...	...	44 to 48	0.19	0.75

GENERAL NOTES:

(a) For reference, see Table I1 Illustration beginning on page 22.

(b) All dimensions are in inches. Tolerances are equal plus and minus except as noted.

NOTES:

(1) Out-of-round is the sum of absolute values of plus and minus tolerance.

(2) This tolerance may not apply in localized areas of formed fittings where increased wall thickness is required to meet design requirements of para. 2.2.

(3) The inside diameter and the nominal wall thicknesses at ends are to be specified by the purchaser.

(4) Unless otherwise specified by the purchaser, these tolerances apply to the nominal inside diameter, which equals the difference between the nominal outside diameter and twice the nominal wall thickness.

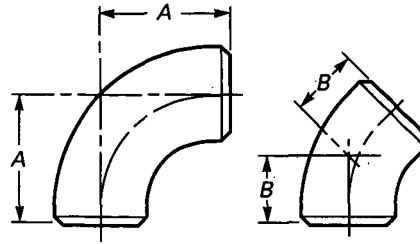

**TABLE 12 DIMENSIONS OF LONG RADIUS ELBOWS**

Nominal Pipe Size (NPS)	Outside Diameter at Bevel	Center-to-End		Nominal Pipe Size (NPS)	Outside Diameter at Bevel	Center-to-End	
		90 Deg Elbows, A	45 Deg Elbows, B			90 Deg Elbows, A	45 Deg Elbows, B
1/2	0.84	1.50	0.62	16	16.00	24.00	10.00
3/4 [Note (1)]	1.05	1.50	0.75	18	18.00	27.00	11.25
1	1.32	1.50	0.88	20	20.00	30.00	12.50
1 1/4	1.66	1.88	1.00	22	22.00	33.00	13.50
1 1/2	1.90	2.25	1.12	24	24.00	36.00	15.00
2	2.38	3.00	1.38	26	26.00	39.00	16.00
2 1/2	2.88	3.75	1.75	28	28.00	42.00	17.25
3	3.50	4.50	2.00	30	30.00	45.00	18.50
3 1/2	4.00	5.25	2.25	32	32.00	48.00	19.75
4	4.50	6.00	2.50	34	34.00	51.00	21.00
5	5.56	7.50	3.12	36	36.00	54.00	22.25
6	6.62	9.00	3.75	38	38.00	57.00	23.62
8	8.62	12.00	5.00	40	40.00	60.00	24.88
10	10.75	15.00	6.25	42	42.00	63.00	26.00
12	12.75	18.00	7.50	44	44.00	66.00	27.38
14	14.00	21.00	8.75	46	46.00	69.00	28.62
				48	48.00	72.00	29.88

GENERAL NOTE: All dimensions are in inches.

NOTE:

(1) A and B dimensions of 1.12 in. and 0.44 in., respectively, may be furnished for NPS 3/4 at the manufacturer's option.

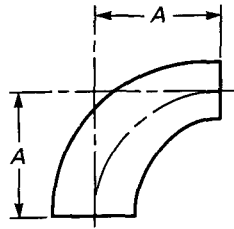
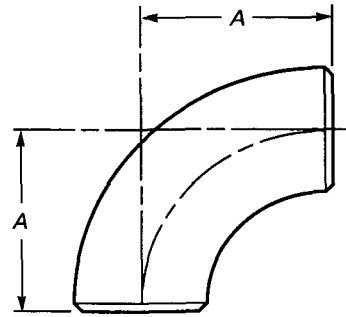
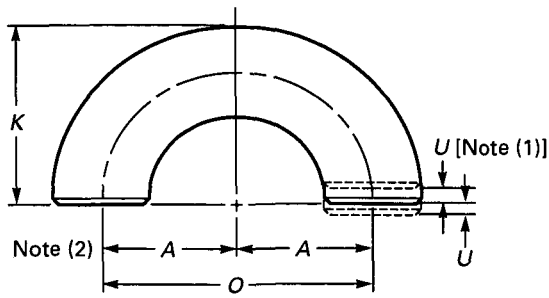

**TABLE I3 DIMENSIONS OF LONG RADIUS REDUCING ELBOWS**

Nominal Pipe Size (NPS)	Outside Diameter at Bevel		Center- to- End, A	Nominal Pipe Size (NPS)	Outside Diameter at Bevel		Center- to- End, A
	Large End	Small End			Large End	Small End	
2 × 1½	2.38	1.90	3.00	10 × 8	10.75	8.62	15.00
2 × 1¼	2.38	1.66	3.00	10 × 6	10.75	6.62	15.00
2 × 1	2.38	1.32	3.00	10 × 5	10.75	5.56	15.00
2½ × 2	2.88	2.38	3.75	12 × 10	12.75	10.75	18.00
2½ × 1½	2.88	1.90	3.75	12 × 8	12.75	8.62	18.00
2½ × 1¼	2.88	1.66	3.75	12 × 6	12.75	6.62	18.00
3 × 2½	3.50	2.88	4.50	14 × 12	14.00	12.75	21.00
3 × 2	3.50	2.38	4.50	14 × 10	14.00	10.75	21.00
3 × 1½	3.50	1.90	4.50	14 × 8	14.00	8.62	21.00
3½ × 3	4.00	3.50	5.25	16 × 14	16.00	14.00	24.00
3½ × 2½	4.00	2.88	5.25	16 × 12	16.00	12.75	24.00
3½ × 2	4.00	2.38	5.25	16 × 10	16.00	10.75	24.00
4 × 3½	4.50	4.00	6.00	18 × 16	18.00	16.00	27.00
4 × 3	4.50	3.50	6.00	18 × 14	18.00	14.00	27.00
4 × 2½	4.50	2.88	6.00	18 × 12	18.00	12.75	27.00
4 × 2	4.50	2.38	6.00	18 × 10	18.00	10.75	27.00
5 × 4	5.56	4.50	7.50	20 × 18	20.00	18.00	30.00
5 × 3½	5.56	4.00	7.50	20 × 16	20.00	16.00	30.00
5 × 3	5.56	3.50	7.50	20 × 14	20.00	14.00	30.00
5 × 2½	5.56	2.88	7.50	20 × 12	20.00	12.75	30.00
6 × 5	6.62	5.56	9.00	20 × 10	20.00	10.75	30.00
6 × 4	6.62	4.50	9.00	24 × 22	24.00	22.00	36.00
6 × 3½	6.62	4.00	9.00	24 × 20	24.00	20.00	36.00
6 × 3	6.62	3.50	9.00	24 × 18	24.00	18.00	36.00
8 × 6	8.62	6.62	12.00	24 × 16	24.00	16.00	36.00
8 × 5	8.62	5.56	12.00	24 × 14	24.00	14.00	36.00
8 × 4	8.62	4.50	12.00	24 × 12	24.00	12.75	36.00

GENERAL NOTE: All dimensions are in inches.





**TABLE 14 DIMENSIONS OF LONG RADIUS RETURNS**

Nominal Pipe Size (NPS)	Outside Diameter at Bevel	Center-to-Center, $O$	Back-to-Face, $K$
1/2	0.84	3.00	1.88
3/4 [Note (3)]	1.05	3.00	2.00
1	1.32	3.00	2.19
1 1/4	1.66	3.75	2.75
1 1/2	1.90	4.50	3.25
2	2.38	6.00	4.19
2 1/2	2.88	7.50	5.19
3	3.50	9.00	6.25
3 1/2	4.00	10.50	7.25
4	4.50	12.00	8.25
5	5.56	15.00	10.31
6	6.62	18.00	12.31
8	8.62	24.00	16.31
10	10.75	30.00	20.38
12	12.75	36.00	24.38
14	14.00	42.00	28.00
16	16.00	48.00	32.00
18	18.00	54.00	36.00
20	20.00	60.00	40.00
22	22.00	66.00	44.00
24	24.00	72.00	48.00

**TABLE 15 DIMENSIONS OF SHORT RADIUS ELBOWS**

Nominal Pipe Size	Outside Diameter at Bevel	Center-to-End, $A$
1	1.32	1.00
1 1/4	1.66	1.25
1 1/2	1.90	1.50
2	2.38	2.00
2 1/2	2.88	2.50
3	3.50	3.00
3 1/2	4.00	3.40
4	4.50	4.00
5	5.56	5.00
6	6.62	6.00
8	8.62	8.00
10	10.75	10.00
12	12.75	12.00
14	14.00	14.00
16	16.00	16.00
18	18.00	18.00
20	20.00	20.00
22	22.00	22.00
24	24.00	24.00

GENERAL NOTE: All dimensions are in inches.

GENERAL NOTE: All dimensions are in inches.

NOTES:

- (1) See Table I1 for tolerance for alignment of ends,  $U$ .
- (2) Dimension  $A$  is equal to one-half of dimension  $O$ .
- (3)  $O$  and  $K$  dimensions of 2.25 in. and 1.69 in. respectively, may be furnished for NPS 3/4 at the manufacturer's option.

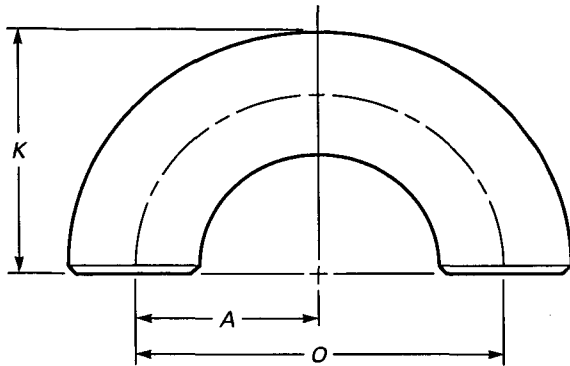
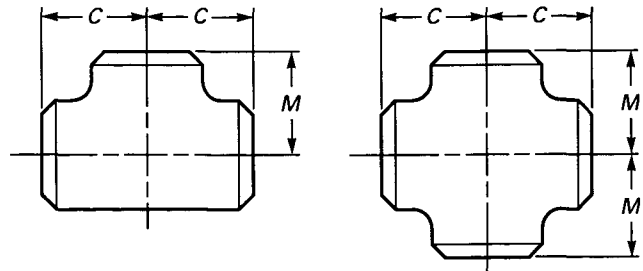

**TABLE 16 DIMENSIONS OF SHORT RADIUS 180 deg RETURNS**

Nominal Pipe Size	Outside Diameter at Bevel	Center-to-Center, $O$	Back-to-Face, $K$
1	1.32	2.00	1.62
1 $\frac{1}{4}$	1.66	2.50	2.06
1 $\frac{1}{2}$	1.90	3.00	2.44
2	2.38	4.00	3.19
2 $\frac{1}{2}$	2.88	5.00	3.94
3	3.50	6.00	4.75
3 $\frac{1}{2}$	4.00	7.00	5.50
4	4.50	8.00	6.25
5	5.56	10.00	7.75
6	6.62	12.00	9.31
8	8.62	16.00	12.31
10	10.75	20.00	15.38
12	12.75	24.00	18.38
14	14.00	28.00	21.00
16	16.00	32.00	24.00
18	18.00	36.00	27.00
20	20.00	40.00	30.00
22	22.00	44.00	33.00
24	24.00	48.00	36.00

**GENERAL NOTES:**

- (a) All dimensions are in inches.
- (b) Dimension  $A$  is equal to one-half of dimension  $O$ .



**TABLE 17 DIMENSIONS OF STRAIGHT TEES AND CROSSES**

Nominal Pipe Size (NPS)	Outside Diameter at Bevel	Center-to-End	
		Run, $C$	Outlet, $M$ [Notes (1) and (2)]
1/2	0.84	1.00	1.00
3/4	1.05	1.12	1.12
1	1.32	1.50	1.50
1 1/4	1.66	1.88	1.88
1 1/2	1.90	2.25	2.25
2	2.38	2.50	2.50
2 1/2	2.88	3.00	3.00
3	3.50	3.38	3.38
3 1/2	4.00	3.75	3.75
4	4.50	4.12	4.12
5	5.56	4.88	4.88
6	6.62	5.62	5.62
8	8.62	7.00	7.00
10	10.75	8.50	8.50
12	12.75	10.00	10.00
14	14.00	11.00	11.00
16	16.00	12.00	12.00
18	18.00	13.50	13.50
20	20.00	15.00	15.00
22	22.00	16.50	16.50
24	24.00	17.00	17.00
26	26.00	19.50	19.50
28	28.00	20.50	20.50
30	30.00	22.00	22.00
32	32.00	23.50	23.50
34	34.00	25.00	25.00
36	36.00	26.50	26.50
38	38.00	28.00	28.00
40	40.00	29.50	29.50
42	42.00	30.00	28.00
44	44.00	32.00	30.00
46	46.00	33.50	31.50
48	48.00	35.00	33.00

GENERAL NOTE: Dimensions are in inches.

**NOTES:**

- (1) Outlet dimension  $M$  for NPS 26 and larger is recommended but not required.
- (2) Dimensions applicable to crosses NPS 24 and smaller.

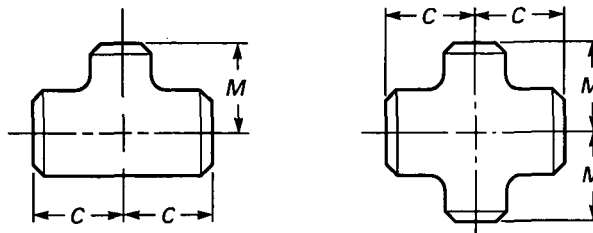

**TABLE 18 DIMENSIONS OF REDUCING OUTLET TEES AND REDUCING OUTLET CROSSES**

Nominal Pipe Size (NPS)	Outside Diameter at Bevel		Center-to-End		Nominal Pipe Size (NPS)	Outside Diameter at Bevel		Center-to-End	
	Run	Outlet	Run, C	Outlet, M [Note (1)]		Run	Outlet	Run, C	Outlet, M [Note (1)]
1/2 x 1/2 x 3/8	0.84	0.68	1.00	1.00	5 x 5 x 4	5.56	4.50	4.88	4.62
1/2 x 1/2 x 1/4	0.84	0.54	1.00	1.00	5 x 5 x 3 1/2	5.56	4.00	4.88	4.50
3/4 x 3/4 x 1/2	1.05	0.84	1.12	1.12	5 x 5 x 3	5.56	3.50	4.88	4.38
3/4 x 3/4 x 3/8	1.05	0.68	1.12	1.12	5 x 5 x 2 1/2	5.56	2.88	4.88	4.25
1 x 1 x 3/4	1.32	1.05	1.50	1.50	5 x 5 x 2	5.56	2.38	4.88	4.12
1 x 1 x 1/2	1.32	0.84	1.50	1.50	6 x 6 x 5	6.62	5.56	5.62	5.38
1 1/4 x 1 1/4 x 1	1.66	1.32	1.88	1.88	6 x 6 x 4	6.62	4.50	5.62	5.12
1 1/4 x 1 1/4 x 3/4	1.66	1.05	1.88	1.88	6 x 6 x 3 1/2	6.62	4.00	5.62	5.00
1 1/4 x 1 1/4 x 1/2	1.66	0.84	1.88	1.88	6 x 6 x 3	6.62	3.50	5.62	4.88
1 1/2 x 1 1/2 x 1 1/4	1.90	1.66	2.25	2.25	6 x 6 x 2 1/2	6.62	2.88	5.62	4.75
1 1/2 x 1 1/2 x 1	1.90	1.32	2.25	2.25	8 x 8 x 6	8.62	6.62	7.00	6.62
1 1/2 x 1 1/2 x 3/4	1.90	1.05	2.25	2.25	8 x 8 x 5	8.62	5.56	7.00	6.38
1 1/2 x 1 1/2 x 1/2	1.90	0.84	2.25	2.25	8 x 8 x 4	8.62	4.50	7.00	6.12
2 x 2 x 1 1/2	2.38	1.90	2.50	2.38	8 x 8 x 3 1/2	8.62	4.00	7.00	6.00
2 x 2 x 1 1/4	2.38	1.66	2.50	2.25	10 x 10 x 8	10.75	8.62	8.50	8.00
2 x 2 x 1	2.38	1.32	2.50	2.00	10 x 10 x 6	10.75	6.62	8.50	7.62
2 x 2 x 3/4	2.38	1.05	2.50	1.75	10 x 10 x 5	10.75	5.56	8.50	7.50
2 1/2 x 2 1/2 x 2	2.88	2.38	3.00	2.75	10 x 10 x 4	10.75	4.50	8.50	7.25
2 1/2 x 2 1/2 x 1 1/2	2.88	1.90	3.00	2.62	12 x 12 x 10	12.75	10.75	10.00	9.50
2 1/2 x 2 1/2 x 1 1/4	2.88	1.66	3.00	2.50	12 x 12 x 8	12.75	8.62	10.00	9.00
2 1/2 x 2 1/2 x 1	2.88	1.32	3.00	2.25	12 x 12 x 6	12.75	6.62	10.00	8.62
3 x 3 x 2 1/2	3.50	2.88	3.38	3.25	12 x 12 x 5	12.75	5.56	10.00	8.50
3 x 3 x 2	3.50	2.38	3.38	3.00	14 x 14 x 12	14.00	12.75	11.00	10.62
3 x 3 x 1 1/2	3.50	1.90	3.38	2.88	14 x 14 x 10	14.00	10.75	11.00	10.12
3 x 3 x 1 1/4	3.50	1.66	3.38	2.75	14 x 14 x 8	14.00	8.62	11.00	9.75
3 1/2 x 3 1/2 x 3	4.00	3.50	3.75	3.62	14 x 14 x 6	14.00	6.62	11.00	9.38
3 1/2 x 3 1/2 x 2 1/2	4.00	2.88	3.75	3.50	16 x 16 x 14	16.00	14.00	12.00	12.00
3 1/2 x 3 1/2 x 2	4.00	2.38	3.75	3.25	16 x 16 x 12	16.00	12.75	12.00	11.62
3 1/2 x 3 1/2 x 1 1/2	4.00	1.90	3.75	3.12	16 x 16 x 10	16.00	10.75	12.00	11.12
4 x 4 x 3 1/2	4.50	4.00	4.12	4.00	16 x 16 x 8	16.00	8.62	12.00	10.75
4 x 4 x 3	4.50	3.50	4.12	3.88	16 x 16 x 6	16.00	6.62	12.00	10.38
4 x 4 x 2 1/2	4.50	2.88	4.12	3.75	18 x 18 x 16	18.00	16.00	13.50	13.00
4 x 4 x 2	4.50	2.38	4.12	3.50	18 x 18 x 14	18.00	14.00	13.50	13.00
4 x 4 x 1 1/2	4.50	1.90	4.12	3.38	18 x 18 x 12	18.00	12.75	13.50	12.62
					18 x 18 x 10	18.00	10.75	13.50	12.12
					18 x 18 x 8	18.00	8.62	13.50	11.75

(continued)

**TABLE 18 DIMENSIONS OF REDUCING OUTLET TEES AND REDUCING OUTLET CROSSES**

Nominal Pipe Size (NPS)	Outside Diameter at Bevel		Center-to-End		Nominal Pipe Size (NPS)	Outside Diameter at Bevel		Center-to-End	
	Run	Outlet	Run, C	Outlet, M [Note (1)]		Run	Outlet	Run, C	Outlet, M [Note (1)]
20 x 20 x 18	20.00	18.00	15.00	14.50	32 x 32 x 24	32.00	24.00	23.50	22.00
20 x 20 x 16	20.00	16.00	15.00	14.00	32 x 32 x 22	32.00	22.00	23.50	21.50
20 x 20 x 14	20.00	14.00	15.00	14.00	32 x 32 x 20	32.00	20.00	23.50	21.00
20 x 20 x 12	20.00	12.75	15.00	13.62	32 x 32 x 18	32.00	18.00	23.50	20.50
20 x 20 x 10	20.00	10.75	15.00	13.12	32 x 32 x 16	32.00	16.00	23.50	20.00
20 x 20 x 8	20.00	8.62	15.00	12.75	32 x 32 x 14	32.00	14.00	23.50	20.00
22 x 22 x 20	22.00	20.00	16.50	16.00	34 x 34 x 32	34.00	32.00	25.00	24.50
22 x 22 x 18	22.00	18.00	16.50	15.50	34 x 34 x 30	34.00	30.00	25.00	24.00
22 x 22 x 16	22.00	16.00	16.50	15.00	34 x 34 x 28	34.00	28.00	25.00	23.50
22 x 22 x 14	22.00	14.00	16.50	15.00	34 x 34 x 26	34.00	26.00	25.00	23.50
22 x 22 x 12	22.00	12.75	16.50	14.62	34 x 34 x 24	34.00	24.00	25.00	23.00
22 x 22 x 10	22.00	10.75	16.50	14.12	34 x 34 x 22	34.00	22.00	25.00	22.50
24 x 24 x 22	24.00	22.00	17.00	17.00	34 x 34 x 20	34.00	20.00	25.00	22.00
24 x 24 x 20	24.00	20.00	17.00	17.00	34 x 34 x 18	34.00	18.00	25.00	21.50
24 x 24 x 18	24.00	18.00	17.00	16.50	34 x 34 x 16	34.00	16.00	25.00	21.00
24 x 24 x 16	24.00	16.00	17.00	16.00	36 x 36 x 34	36.00	34.00	26.50	26.00
24 x 24 x 14	24.00	14.00	17.00	16.00	36 x 36 x 32	36.00	32.00	26.50	25.50
24 x 24 x 12	24.00	12.75	17.00	15.62	36 x 36 x 30	36.00	30.00	26.50	25.00
24 x 24 x 10	24.00	10.75	17.00	15.12	36 x 36 x 28	36.00	28.00	26.50	24.50
26 x 26 x 24	26.00	24.00	19.50	19.00	36 x 36 x 26	36.00	26.00	26.50	24.50
26 x 26 x 22	26.00	22.00	19.50	18.50	36 x 36 x 24	36.00	24.00	26.50	24.00
26 x 26 x 20	26.00	20.00	19.50	18.00	36 x 36 x 22	36.00	22.00	26.50	23.50
26 x 26 x 18	26.00	18.00	19.50	17.50	36 x 36 x 20	36.00	20.00	26.50	23.00
26 x 26 x 16	26.00	16.00	19.50	17.00	36 x 36 x 18	36.00	18.00	26.50	22.50
26 x 26 x 14	26.00	14.00	19.50	17.00	36 x 36 x 16	36.00	16.00	26.50	22.00
26 x 26 x 12	26.00	12.75	19.50	16.62	38 x 38 x 36	38.00	36.00	28.00	28.00
28 x 28 x 26	28.00	26.00	20.50	20.50	38 x 38 x 34	38.00	34.00	28.00	27.50
28 x 28 x 24	28.00	24.00	20.50	20.00	38 x 38 x 32	38.00	32.00	28.00	27.00
28 x 28 x 22	28.00	22.00	20.50	19.50	38 x 38 x 30	38.00	30.00	28.00	26.50
28 x 28 x 20	28.00	20.00	20.50	19.00	38 x 38 x 28	38.00	28.00	28.00	25.50
28 x 28 x 18	28.00	18.00	20.50	18.50	38 x 38 x 26	38.00	26.00	28.00	25.50
28 x 28 x 16	28.00	16.00	20.50	18.00	38 x 38 x 24	38.00	24.00	28.00	25.00
28 x 28 x 14	28.00	14.00	20.50	18.00	38 x 38 x 22	38.00	22.00	28.00	24.50
28 x 28 x 12	28.00	12.75	20.50	17.62	38 x 38 x 20	38.00	20.00	28.00	24.00
30 x 30 x 28	30.00	28.00	22.00	21.50	38 x 38 x 18	38.00	18.00	28.00	23.50
30 x 30 x 26	30.00	26.00	22.00	21.50	40 x 40 x 38	40.00	38.00	29.50	29.50
30 x 30 x 24	30.00	24.00	22.00	21.00	40 x 40 x 36	40.00	36.00	29.50	29.00
30 x 30 x 22	30.00	22.00	22.00	20.50	40 x 40 x 34	40.00	34.00	29.50	28.50
30 x 30 x 20	30.00	20.00	22.00	20.00	40 x 40 x 32	40.00	32.00	29.50	28.00
30 x 30 x 18	30.00	18.00	22.00	19.50	40 x 40 x 30	40.00	30.00	29.50	27.50
30 x 30 x 16	30.00	16.00	22.00	19.00	40 x 40 x 28	40.00	28.00	29.50	26.50
30 x 30 x 14	30.00	14.00	22.00	19.00	40 x 40 x 26	40.00	26.00	29.50	26.50
30 x 30 x 12	30.00	12.75	22.00	18.62	40 x 40 x 24	40.00	24.00	29.50	26.00
30 x 30 x 10	30.00	10.75	22.00	18.12	40 x 40 x 22	40.00	22.00	29.50	25.50
32 x 32 x 30	32.00	30.00	23.50	23.00	40 x 40 x 20	40.00	20.00	29.50	25.00
32 x 32 x 28	32.00	28.00	23.50	22.50	40 x 40 x 18	40.00	18.00	29.50	24.50
32 x 32 x 26	32.00	26.00	23.50	22.50	42 x 42 x 40	42.00	40.00	30.00	28.00
					40 x 40 x 38	42.00	38.00	30.00	28.00

(continued)

**TABLE 18 DIMENSIONS OF REDUCING OUTLET TEES AND REDUCING OUTLET CROSSES**

Nominal Pipe Size (NPS)	Outside Diameter at Bevel		Center-to-End		Nominal Pipe Size (NPS)	Outside Diameter at Bevel		Center-to-End	
	Run	Outlet	Run, C	Outlet, M [Note (1)]		Run	Outlet	Run, C	Outlet, M [Note (1)]
42 × 42 × 36	42.00	36.00	30.00	28.00	46 × 46 × 44	46.00	44.00	33.50	31.50
42 × 42 × 34	42.00	34.00	30.00	28.00	46 × 46 × 42	46.00	42.00	33.50	31.00
42 × 42 × 32	42.00	32.00	30.00	28.00	46 × 46 × 40	46.00	40.00	33.50	30.50
42 × 42 × 30	42.00	30.00	30.00	28.00	46 × 46 × 38	46.00	38.00	33.50	30.00
42 × 42 × 28	42.00	28.00	30.00	27.50	46 × 46 × 36	46.00	36.00	33.50	30.00
42 × 42 × 26	42.00	26.00	30.00	27.50	46 × 46 × 34	46.00	34.00	33.50	29.50
42 × 42 × 24	42.00	24.00	30.00	26.00	46 × 46 × 32	46.00	32.00	33.50	29.50
42 × 42 × 22	42.00	22.00	30.00	26.00	46 × 46 × 30	46.00	30.00	33.50	29.00
42 × 42 × 20	42.00	20.00	30.00	26.00	46 × 46 × 28	46.00	28.00	33.50	29.00
42 × 42 × 18	42.00	18.00	30.00	25.50	46 × 46 × 26	46.00	26.00	33.50	29.00
42 × 42 × 16	42.00	16.00	30.00	25.00	46 × 46 × 24	46.00	24.00	33.50	28.50
					46 × 46 × 22	46.00	22.00	33.50	28.50
44 × 44 × 42	44.00	42.00	32.00	30.00					
44 × 44 × 40	44.00	40.00	32.00	29.50	48 × 48 × 46	48.00	46.00	35.00	33.00
44 × 44 × 38	44.00	38.00	32.00	29.00	48 × 48 × 44	48.00	44.00	35.00	33.00
44 × 44 × 36	44.00	36.00	32.00	28.50	48 × 48 × 42	48.00	42.00	35.00	32.00
44 × 44 × 34	44.00	34.00	32.00	28.50	48 × 48 × 40	48.00	40.00	35.00	32.00
44 × 44 × 32	44.00	32.00	32.00	28.00	48 × 48 × 38	48.00	38.00	35.00	32.00
44 × 44 × 30	44.00	30.00	32.00	28.00	48 × 48 × 36	48.00	36.00	35.00	31.00
44 × 44 × 28	44.00	28.00	32.00	27.50	48 × 48 × 34	48.00	34.00	35.00	31.00
44 × 44 × 26	44.00	26.00	32.00	27.50	48 × 48 × 32	48.00	32.00	35.00	31.00
44 × 44 × 24	44.00	24.00	32.00	27.50	48 × 48 × 30	48.00	30.00	35.00	30.00
44 × 44 × 22	44.00	22.00	32.00	27.00	48 × 48 × 28	48.00	28.00	35.00	30.00
44 × 44 × 20	44.00	20.00	32.00	27.00	48 × 48 × 26	48.00	26.00	35.00	30.00
					48 × 48 × 24	48.00	24.00	35.00	29.00
					48 × 48 × 22	48.00	22.00	35.00	29.00

GENERAL NOTE: All dimensions are in inches.

NOTE:

(1) Outlet dimension *M* for run sizes 14 and larger is recommended but not required.

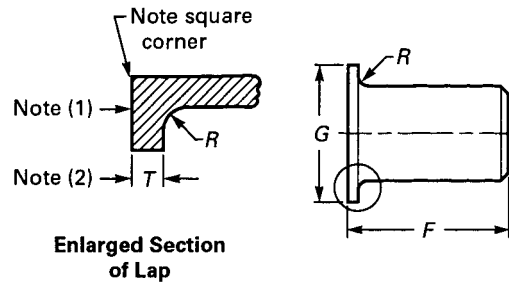

**TABLE 19 DIMENSIONS OF LAP JOINT STUB ENDS**

Nominal Pipe Size (NPS)	Outside Diameter of Barrel		Long Pattern Length, <i>F</i> [Notes (3), (4)]	Short Pattern Length, <i>F</i> [Notes (3), (4)]	Radius of Fillet, <i>R</i> [Note (5)]	Diameter of Lap, <i>G</i> [Note (6)]
	Max.	Min.				
1/2	0.896	0.809	3.00	2.00	0.12	1.38
3/4	1.106	1.019	3.00	2.00	0.12	1.38
1	1.376	1.284	4.00	2.00	0.12	2.00
1 1/4	1.716	1.629	4.00	2.00	0.19	2.50
1 1/2	1.965	1.869	4.00	2.00	0.25	2.88
2	2.456	2.344	6.00	2.50	0.31	3.62
2 1/2	2.966	2.844	6.00	2.50	0.31	4.12
3	3.596	3.469	6.00	2.50	0.38	5.00
3 1/2	4.096	3.969	6.00	3.00	0.38	5.50
4	4.593	4.469	6.00	3.00	0.44	5.19
5	5.683	5.532	8.00	3.00	0.44	7.31
6	6.743	6.594	8.00	3.50	0.50	8.50
8	8.743	8.594	8.00	4.00	0.50	10.62
10	10.913	10.719	10.00	5.00	0.50	12.75
12	12.913	12.719	10.00	6.00	0.50	15.00
14	14.170	13.969	12.00	6.00	0.50	16.25
16	16.180	15.969	12.00	6.00	0.50	18.50
18	18.190	17.969	12.00	6.00	0.50	21.00
20	20.240	19.969	12.00	6.00	0.50	23.00
22	22.240	21.969	12.00	6.00	0.50	25.25
24	24.240	23.969	12.00	6.00	0.50	27.25

**GENERAL NOTES:**

- (a) All dimensions are in inches.
- (b) See Table I1 for tolerances.
- (c) Service conditions and joint construction often dictate stub end length requirements. Therefore, the purchaser must specify long or short pattern fitting when ordering.

**NOTES:**

- (1) Gasket face finish shall be in accordance with ASME B16.5 for raised face flanges.
- (2) The lap thickness *T* shall not be less than nominal pipe wall thickness. See Table I1 for tolerance.
- (3) When short pattern stub ends are used with larger flanges in Classes 300 and 600, and with most sizes in Classes 900 and higher, and when long pattern stub ends are used with larger flanges in Classes 1500 and 2500, it may be necessary to increase the length of the stub ends in order to avoid covering the weld with the flange. Such increases in length shall be a matter of agreement between the manufacturer and the purchaser.
- (4) When special facings such as tongue and groove, male and female, etc., are employed, additional lap thickness must be provided and such additional thickness shall be in addition to (not included in) the basic length *F*.
- (5) These dimensions conform to the radius established for lap joint flanges in ASME B16.5, Pipe Flanges and Flanged Fittings.
- (6) This dimension conforms to standard machine facings shown in ASME B16.5. The back face of the lap shall be machined to conform to the surface on which it seats. Where ring joint facings are to be applied, use dimension *K* as given in ASME B16.5.

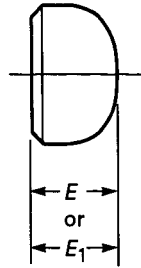

TABLE I10 DIMENSIONS OF CAPS

Nominal Pipe Size (NPS)	Outside Diameter at Bevel	Length, $E$ [Note (1)]	Limiting Wall Thickness for Length $E$	Length, $E_1$ [Note (2)]	Nominal Pipe Size (NPS)	Outside Diameter at Bevel	Length, $E$ [Note (1)]	Limiting Wall Thickness for Length $E$	Length, $E_1$ [Note (2)]
1/2	0.84	1.00	0.18	1.00	18	18.00	8.00	0.50	9.00
3/4	1.05	1.00	0.15	1.00	20	20.00	9.00	0.50	10.00
1	1.32	1.50	0.18	1.50	22	22.00	10.00	0.50	10.00
1 1/4	1.66	1.50	0.19	1.50	24	24.00	10.50	0.50	12.00
1 1/2	1.90	1.50	0.20	1.50	26	26.00	10.50	...	...
2	2.38	1.50	0.22	1.75	28	28.00	10.50	...	...
2 1/2	2.88	1.50	0.28	2.00	30	30.00	10.50	...	...
3	3.50	2.00	0.30	2.50	32	32.00	10.50	...	...
3 1/2	4.00	2.50	0.32	3.00	34	34.00	10.50	...	...
4	4.50	2.50	0.34	3.00	36	36.00	10.50	...	...
5	5.56	3.00	0.38	3.50	38	38.00	12.00	...	...
6	6.62	3.50	0.43	4.00	40	40.00	12.00	...	...
8	8.62	4.00	0.50	5.00	42	42.00	12.00	...	...
10	10.75	5.00	0.50	6.00	44	44.00	13.50	...	...
12	12.75	6.00	0.50	7.00	46	46.00	13.50	...	...
14	14.00	6.50	0.50	7.50	48	48.00	13.50	...	...
16	16.00	7.00	0.50	8.00					

## GENERAL NOTES:

(a) All dimensions are in inches.

(b) The shape of these caps shall be ellipsoidal and shall conform to the shape requirements as given in the ASME Boiler and Pressure Vessel Code.

## NOTES:

(1) Length  $E$  applies for thickness not exceeding that given in column "Limiting Wall Thickness for Length  $E$ ."(2) Length  $E_1$  applies for thickness greater than that given in column "Limiting Wall Thickness" for NPS 24 and smaller. For NPS 26 and larger, length  $E_1$  shall be by agreement between the manufacturer and purchaser.

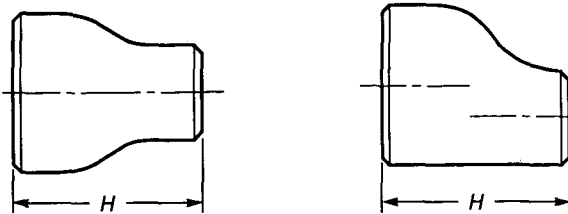

Note (1)

TABLE I11 DIMENSIONS OF REDUCERS

Nominal Pipe Size (NPS)	Outside Diameter at Bevel		End-to-End, H	Nominal Pipe Size (NPS)	Outside Diameter at Bevel		End-to-End, H
	Large End	Small End			Large End	Small End	
3/4 x 1/2	1.05	0.84	1.50	5 x 3	5.56	3.50	5.00
3/4 x 3/8	1.05	0.68	1.50	5 x 2 1/2	5.56	2.88	5.00
1 x 3/4	1.32	1.05	2.00	5 x 2	5.56	2.38	5.00
1 x 1/2	1.32	0.84	2.00				
				6 x 5	6.62	5.56	5.50
1 1/4 x 1	1.66	1.32	2.00	6 x 4	6.62	4.50	5.50
1 1/4 x 3/4	1.66	1.05	2.00	6 x 3 1/2	6.62	4.00	5.50
1 1/4 x 1/2	1.66	0.84	2.00	6 x 3	6.62	3.50	5.50
				6 x 2 1/2	6.62	2.88	5.50
1 1/2 x 1 1/4	1.90	1.66	2.50				
1 1/2 x 1	1.90	1.32	2.50	8 x 6	8.62	6.62	6.00
1 1/2 x 3/4	1.90	1.05	2.50	8 x 5	8.62	5.56	6.00
1 1/2 x 1/2	1.90	0.84	2.50	8 x 4	8.62	4.50	6.00
				8 x 3 1/2	8.62	4.00	6.00
2 x 1 1/2	2.38	1.90	3.00				
2 x 1 1/4	2.38	1.66	3.00	10 x 8	10.75	8.62	7.00
2 x 1	2.38	1.32	3.00	10 x 6	10.75	6.62	7.00
2 x 3/4	2.38	1.05	3.00	10 x 5	10.75	5.56	7.00
				10 x 4	10.75	4.50	7.00
2 1/2 x 2	2.88	2.38	3.50				
2 1/2 x 1 1/2	2.88	1.90	3.50	12 x 10	12.75	10.75	8.00
2 1/2 x 1 1/4	2.88	1.66	3.50	12 x 8	12.75	8.62	8.00
2 1/2 x 1	2.88	1.32	3.50	12 x 6	12.75	6.62	8.00
				12 x 5	12.75	5.56	8.00
3 x 2 1/2	3.50	2.88	3.50				
3 x 2	3.50	2.38	3.50	14 x 12	14.00	12.75	13.00
3 x 1 1/2	3.50	1.90	3.50	14 x 10	14.00	10.75	13.00
3 x 1 1/4	3.50	1.66	3.50	14 x 8	14.00	8.62	13.00
				14 x 6	14.00	6.62	13.00
3 1/2 x 3	4.00	3.50	4.00				
3 1/2 x 2 1/2	4.00	2.88	4.00	16 x 14	16.00	14.00	14.00
3 1/2 x 2	4.00	2.38	4.00	16 x 12	16.00	12.75	14.00
3 1/2 x 1 1/2	4.00	1.90	4.00	16 x 10	16.00	10.75	14.00
3 1/2 x 1 1/4	4.00	1.66	4.00	16 x 8	16.00	8.62	14.00
4 x 3 1/2	4.50	4.00	4.00	18 x 16	18.00	16.00	15.00
4 x 3	4.50	3.50	4.00	18 x 14	18.00	14.00	15.00
4 x 2 1/2	4.50	2.88	4.00	18 x 12	18.00	12.75	15.00
4 x 2	4.50	2.38	4.00	18 x 10	18.00	10.75	15.00
4 x 1 1/2	4.50	1.90	4.00				
				20 x 18	20.00	18.00	20.00
5 x 4	5.56	4.50	5.00	20 x 16	20.00	16.00	20.00
5 x 3 1/2	5.56	4.00	5.00	20 x 14	20.00	14.00	20.00

(continued)



TABLE I11 DIMENSIONS OF REDUCERS

Nominal Pipe Size (NPS)	Outside Diameter at Bevel		End-to-End, <i>H</i>	Nominal Pipe Size (NPS)	Outside Diameter at Bevel		End-to-End, <i>H</i>
	Large End	Small End			Large End	Small End	
20 × 12	20.00	12.75	20.00	36 × 30	36.00	30.00	24.00
				36 × 26	36.00	26.00	24.00
22 × 20	22.00	20.00	20.00	36 × 24	36.00	24.00	24.00
22 × 18	22.00	18.00	20.00				
22 × 16	22.00	16.00	20.00	38 × 36	38.00	36.00	24.00
22 × 14	22.00	14.00	20.00	38 × 34	38.00	34.00	24.00
				38 × 32	38.00	32.00	24.00
24 × 22	24.00	22.00	20.00	38 × 30	38.00	30.00	24.00
24 × 20	24.00	20.00	20.00	38 × 28	38.00	28.00	24.00
24 × 18	24.00	18.00	20.00	38 × 26	38.00	26.00	24.00
24 × 16	24.00	16.00	20.00				
				40 × 38	40.00	38.00	24.00
26 × 24	26.00	24.00	24.00	40 × 36	40.00	36.00	24.00
26 × 22	26.00	22.00	24.00	40 × 34	40.00	34.00	24.00
26 × 20	26.00	20.00	24.00	40 × 32	40.00	32.00	24.00
26 × 18	26.00	18.00	24.00	40 × 30	40.00	30.00	24.00
28 × 26	28.00	26.00	24.00	42 × 40	42.00	40.00	24.00
28 × 24	28.00	24.00	24.00	42 × 38	42.00	38.00	24.00
28 × 20	28.00	20.00	24.00	42 × 36	42.00	36.00	24.00
28 × 18	28.00	18.00	24.00	42 × 34	42.00	34.00	24.00
				42 × 32	42.00	32.00	24.00
30 × 28	30.00	28.00	24.00	42 × 30	42.00	30.00	24.00
30 × 26	30.00	26.00	24.00				
30 × 24	30.00	24.00	24.00	44 × 42	44.00	42.00	24.00
30 × 20	30.00	20.00	24.00	44 × 40	44.00	40.00	24.00
				44 × 38	44.00	38.00	24.00
32 × 30	32.00	30.00	24.00	44 × 36	44.00	36.00	24.00
32 × 28	32.00	28.00	24.00				
32 × 26	32.00	26.00	24.00	46 × 44	46.00	44.00	28.00
32 × 24	32.00	24.00	24.00	46 × 42	46.00	42.00	28.00
				46 × 40	46.00	40.00	28.00
34 × 32	34.00	32.00	24.00	46 × 38	46.00	38.00	28.00
34 × 30	34.00	30.00	24.00				
34 × 26	34.00	26.00	24.00	48 × 46	48.00	46.00	28.00
34 × 24	34.00	24.00	24.00	48 × 44	48.00	44.00	28.00
				48 × 42	48.00	42.00	28.00
36 × 34	36.00	34.00	24.00	48 × 40	48.00	40.00	28.00
36 × 32	36.00	32.00	24.00				

## GENERAL NOTES:

(a) All dimensions are in inches.

## NOTE:

(1) While the figure illustrates a "bell shaped" reducer, the use of conical reducer is not prohibited.

## MANDATORY APPENDIX II REFERENCES

The following is a list of standards and specifications referenced in this Standard showing the year of approval.

ASME B16.5-1996, Pipe Flanges and Flanged Fittings  
 ASME B16.25-1997, Butt-welding Ends  
 ASME B16.49-2000, Factory-Made Wrought Steel Butt-welding Induction Bends for Transportation and Distribution Systems  
 ASME B31, Code for Pressure Piping  
 ASME B36.10M-1996, Welded and Seamless Wrought Steel Pipes  
 ASME B36.19M-1985(R1994), Stainless Steel Pipe  
 ASME BPVC-1995, ASME Boiler and Pressure Vessel Code

Publisher: American Society of Mechanical Engineers (ASME International), Three Park Avenue, New York, NY 10016; Order Department: 22 Law Drive, Box 2300, Fairfield, NJ 07007

ASTM A 234-00, Standard Specification for Piping Fittings of Wrought Carbon Steel and Alloy Steel for Moderate and High Temperature Service  
 ASTM A 403-00b, Standard Specification for Wrought Austenitic Stainless Steel Piping Fittings  
 ASTM A 420-00a, Standard Specification for Piping Fittings of Wrought Carbon Steel and Alloy Steel for Low-Temperature Service  
 ASTM A 815/A 815M-00, Standard Specification for Wrought Ferritic, Ferritic/Austenitic and Martensitic Stainless Steel Piping Fittings  
 ASTM B 361-95, Standard Specification for Factory-Made Wrought Aluminum and Aluminum-Alloy Welding Fittings

ASTM B 363-00, Standard Specification for Seamless and Welded Unalloyed Titanium and Titanium Alloy Welding Fittings

ASTM B 366-00, Standard Specifications for Factory-Made Wrought Nickel and Nickel Alloy Fittings  
 ASTM E 29-93a, Standard Practice for Using Significant Digits in Test Data to Determine Conformance With Specifications

Publisher: American Society for Testing and Materials (ASTM), 100 Barr Harbor Drive, West Conshohocken, PA 19428

ISO 6708:1995, Pipework Components — Definition and Selection of DN (Nominal Size)

ISO 9000-1:1994, Quality Management and Quality Assurance Standards — Part 1: Guidelines for Selection and Use

ISO 9000-2:1997, Quality Management and Quality Assurance Standards — Part 2: Generic Guidelines for the Application of ISO 9001, ISO 9002, and ISO 9003

ISO 9000-3:1997, Quality Management and Quality Assurance Standards — Part 3: Guidelines for the Application of ISO 9001:1994 to the Development, Supply, Installation and Maintenance of Computer Software

ISO 9001:1994, Quality Systems — Model for Quality Assurance in Design, Development, Production, Installation and Servicing

ISO 9002:1994, Quality Systems — Model for Quality Assurance in Production, Installation and Servicing  
 ISO 9003:1994, Quality Systems — Model for Quality Assurance in Final Inspection and Test

Publisher: International Organization for Standardization (ISO), 1 rue de Varembé, Case Postale 131, CH-1211, Genève 20, Switzerland/Suisse

## NONMANDATORY APPENDIX A QUALITY SYSTEM PROGRAM

The products manufactured in accordance with this Standard shall be produced under a quality system program following the principles of an appropriate standard from the ISO 9000 series<sup>1</sup>. A determination of the need for registration and/or certification of the product manufacturer's quality system by an independent organization shall be the responsibility of the manufacturer. The detailed documentation demonstrating program compliance shall be available to the purchaser at the manufacturer's facility. A written summary description of the program utilized by the product manufacturer shall be available to the purchaser upon request. The product manufacturer is defined as the entity whose name or trademark appears on the product in accordance with the marking or identification requirements of this Standard.

---

<sup>1</sup> The series is also available from the American National Standards Institute (ANSI) and the American Society for Quality Control (ASQC) as American National Standards that are identified by a prefix "Q" replacing the prefix "ISO". Each standard of the series is listed under references.

ISBN 0-7918-2666-X

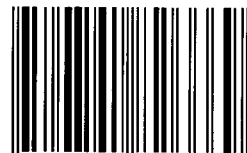

9 780791 826669



J10901